

ABB DRIVES

ACS880-01...+C135 drives with flange mounting kit Supplement



ACS880-01...+C135 drives with flange mounting kit

Supplement

Table of contents



3. Mechanical installation



Table of contents

1. Introduction to the supplement

Contents of this chapter	7
Applicability	7
Target audience	7
Purpose of the supplement	7
Related documents	8

2. Hardware description

Contents of this chapter	9
Product overview	9
Layout and mounting position	9
Tilted position, R1 to R5	10
Upright position, R6 to R9	11
Degree of protection	11
Special requirements	12
Ordering codes	12



3. Mechanical installation

Contents of this chapter	13
Safety	13
Examining the installation site	14
Additional requirements for cabinet installations	14
Required tools	14
Moving the drive	14
Unpacking and examining the delivery	14
Transport package contents	14
Frames R1 to R5	15
Frames R6 to R9	16
Flange mounting kit package contents	17
Frames R1 to R3	17
Frames R4 to R5	18
Frames R6 to R9	19
Mounting template	19
Installing the drive	20
Free space requirements	20
Installing drives above one another	21
Installation procedure	22
Frames R1 to R3	22
Frames R4 to R5	31
Frames R6 to R9	40

4. Dimension drawings

Contents of this chapter	45
Frame R1	46
Attaching points and opening dimensions	47
Frame R2	48
Attaching points and opening dimensions	49
Frame R3	50
Attaching points and opening dimensions	51
Frame R4	52
Attaching points and opening dimensions	54
Frame R5	55
Attaching points and opening dimensions	57
Frame R6	58
Attaching points and opening dimensions	60
Frame R7	61
Attaching points and opening dimensions	63
Frame R8	64
Attaching points and opening dimensions	66
Frame R9	67
Attaching points and opening dimensions	69



5. Mounting examples

Contents of this chapter	71
Frame R1	72
Frame R2	75
Frame R3	78
Frame R4	81
Frame R5	84
Frame R6	87
Frame R7	90
Frame R8	93
Frame R9	96

Further information



Introduction to the supplement

Contents of this chapter

This chapter describes the supplement.

Applicability

This supplement applies to ACS880-01 drive with flange mounting kits (option +C135).

Target audience

This supplement is intended for people who plan the installation and install the drive with the flange mounting kit. Read the supplement before you work on the drive. You are expected to know the fundamentals of electricity, wiring, electrical components and electrical schematic symbols.

The supplement is written for readers worldwide. Both SI and imperial units are shown.

Purpose of the supplement

This supplement tells you how to install the drive mechanically onto an opening in a mounting plate with the flange mounting kit.

Related documents

Drive hardware manuals and guides	Code (English)	Note
<i>ACS880-01...+C135 drives with flange mounting kit supplement</i>	3AXD50000349814	
<i>ACS880-01...+C135 frames R1 to R3 flange mounting kit quick installation guide</i>	3AXD50000026158	
<i>ACS880-01...+C135 frames R4 to R5 flange mounting kit quick installation guide</i>	3AXD50000026159	
<i>ACS880-01...+C135, ACS580-01...+C135, ACH580-01...+C135 and ACQ580-01...+C135 frames R6 to R9 flange mounting kit quick installation guide</i>	3AXD50000019099	
<i>ACS880-01 hardware manual</i>	3AUA0000078093	
<i>ACS880-01 quick installation guide for frames R1 to R3</i>	3AUA0000085966	
<i>ACS880-01 quick installation guide for frames R4 and R5</i>	3AUA0000099663	
<i>ACS880-01 quick installation guide for frames R6 to R9</i>	3AUA0000099689	

You can find manuals and other product documents in PDF format on the Internet. See section [Document library on the Internet](#) on the inside of the back cover. For manuals not available in the Document library, contact your local ABB representative. The code below opens an online listing of the manuals applicable to the product.



[ACS880-01 manuals](#)



Hardware description

Contents of this chapter

This chapter describes the flange mounting kit.

Product overview

The flange mounting kit contains brackets for attaching the drive onto a mounting plate. The heat sink of the drive can be located in the cooling air channel and the front part on the other side of the mounting plate. The drive cable box and IP55 (UL Type 12) front cover are compatible with the flange mounting kit.

Layout and mounting position

The flange-mounted drive is installed in a tilted or an upright position depending on the drive type.

Tilted position, R1 to R5

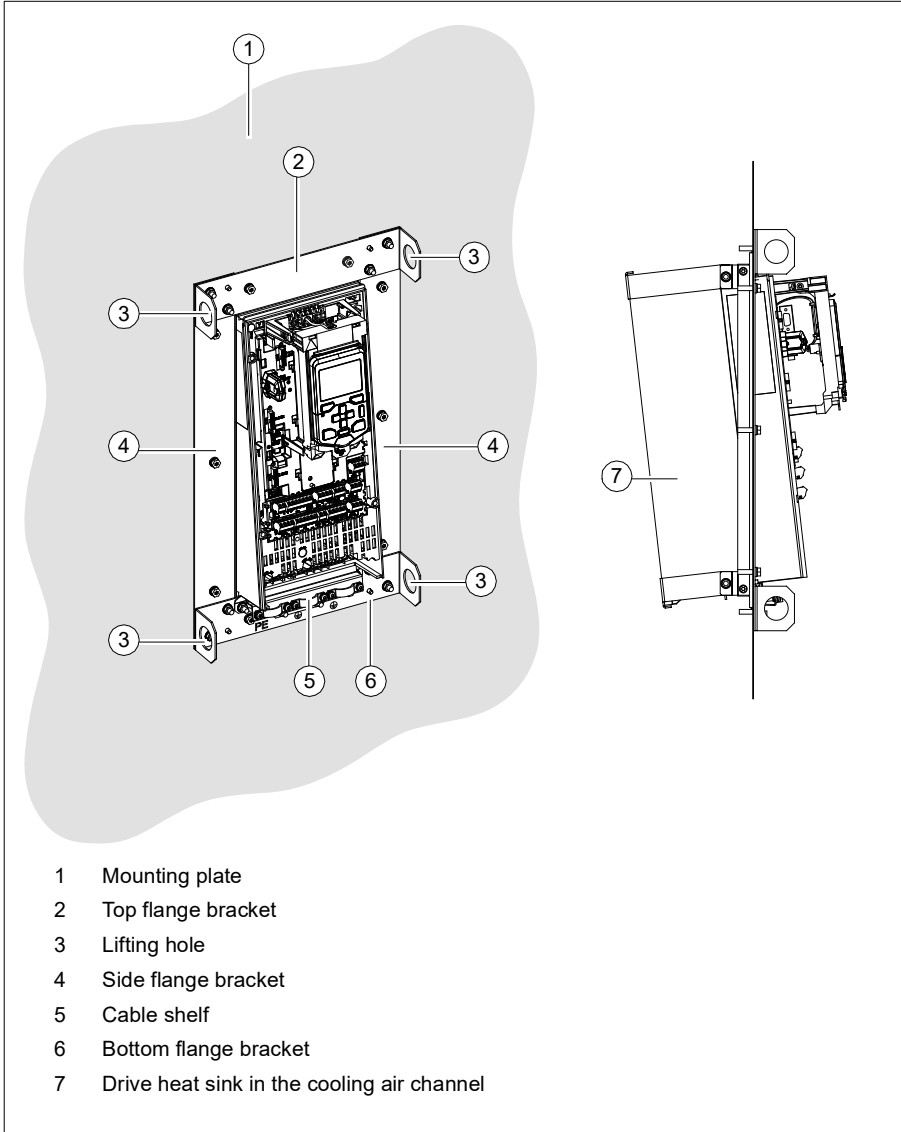

Upright position, R6 to R9

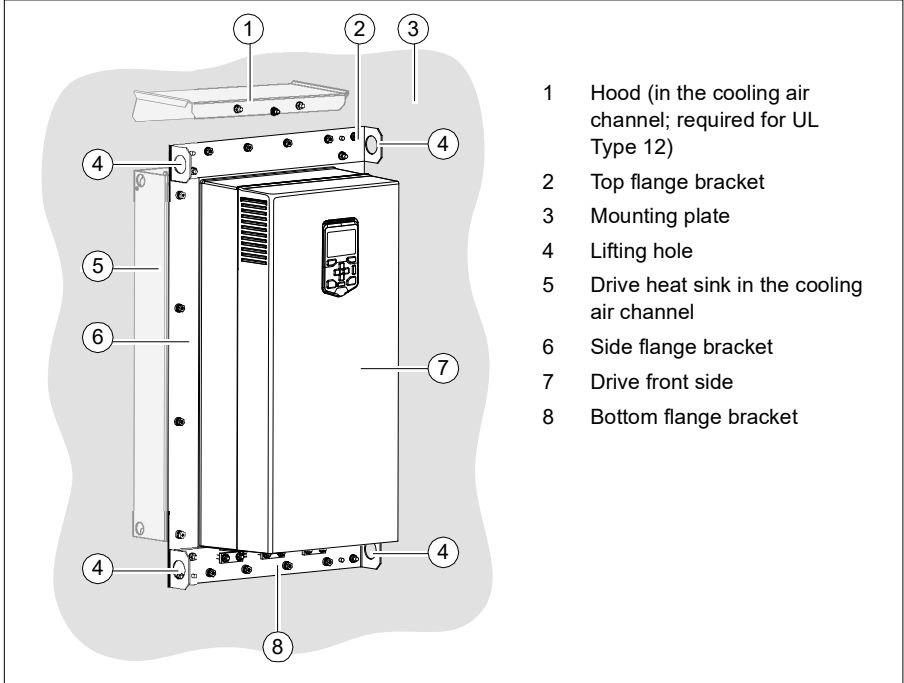

Degree of protection

This table shows the degree of protection of the flange-mounted drive.

Plus code	Degree of protection	Degree of protection with flange	
		Front	Back
-	IP21 (UL Type 1)	IP20 (UL Open Type)	IP55 (UL Type 12)
P940	IP20 (UL Open Type)	IP20 (UL Open Type)	IP55 (UL Type 12)
P944	IP20 (UL Open Type)	IP20 (UL Open Type)	IP55 (UL Type 12)
B056	IP55 (UL Type 12)	IP20 (UL Open Type)	IP55 (UL Type 12)

■ Special requirements

Frame size	Special requirement
R1	Insert sealing plug.
R2	
R3	
R4	Insert sealing plug and attach sealing tapes.
R5	

Ordering codes

The flange mounting kit is a plus code option (+C135) or can be ordered with these ordering codes also separately.

Frame size	Ordering code
R1	3AXD50000024175
R2	3AXD50000024176
R3	3AXD50000024177
R4	3AXD50000027190
R5	3AXD50000018602
R6	3AXD50000018852
R7	3AXD50000018853
R8	3AXD50000018854
R9	3AXD50000018855

Note: The separately ordered flange retrofit kit is compatible only with drives that have been produced after 2016-01-01.

3

Mechanical installation

Contents of this chapter

This chapter describes how to install the drive with the flange mounting kit mechanically.

Safety

Obey the general safety instructions in the hardware manual and the task-specific instructions in this supplement.

Wear protective gloves and long sleeves. Some parts have sharp edges.



WARNING! For frame sizes R6 to R9: Use the lifting eyes of the drive when you lift the drive. Do not tilt the drive. The drive is heavy and its center of gravity is high. An overturning drive can cause physical injury.

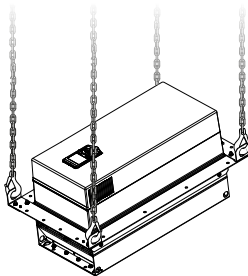
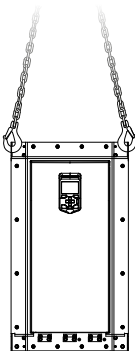

Examining the installation site

Make sure that the installation site agrees with these requirements:

- The installation site has sufficient ventilation to prevent overheating of the drive. See section *Losses, cooling data and noise* in the hardware manual for the required air flow in the cooling air channel and in the front part of the drive.
- The operation conditions of the drive agree with the specifications in section *Ambient conditions* in the hardware manual.
- The mounting plate is vertical, not flammable and strong enough to hold the weight of the drive module.
- The material below the installation is not flammable.
- There is enough free space above and below the drive for cooling air flow, service and maintenance. There is enough free space in front of the drive for operation, service and maintenance. See section *Free space requirements* on page 20 and *Dimensions, weights and free space requirements* in the hardware manual.

Additional requirements for cabinet installations

Make sure that the cooling air gratings of the drive will not be covered. Make sure that the required cooling air change is achieved. In a totally closed cabinet with no forced ventilation, a fan for circulating the air inside the cabinet may be needed.



Required tools

To install the drive mechanically, you need the following tools:

- drill with suitable bits
- screwdriver.

Moving the drive

Move the drive in its transport package to the installation site. Use a pallet truck when you move a heavy drive package.

Unpacking and examining the delivery

■ Transport package contents

The flange mounting kit package is either in the drive package, tied with straps onto the drive package or sent separately. Examine that all items are present and there are no signs of damage. Read the data on the type designation label of the drive to make sure that the drive is of the correct type.

Frames R1 to R5

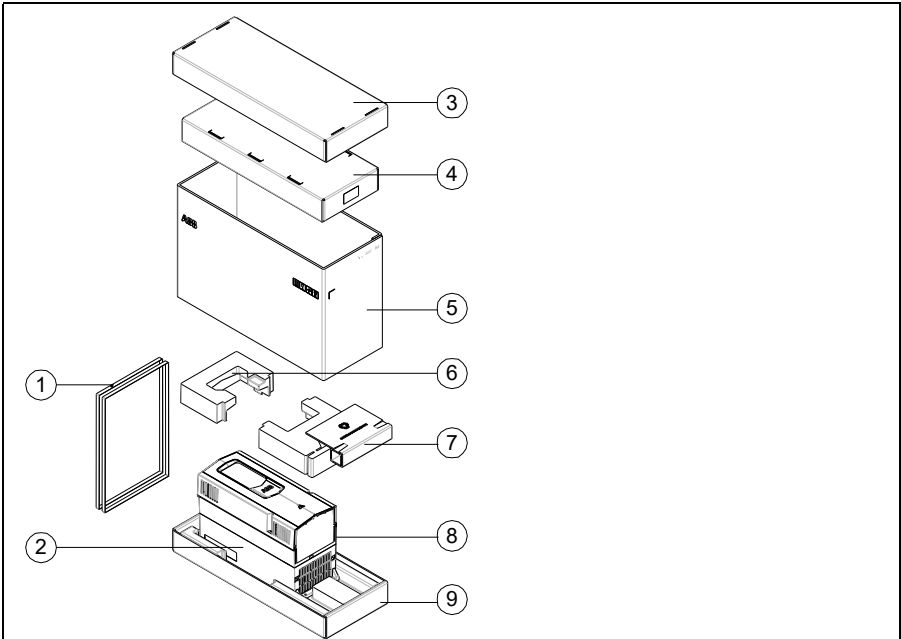

Item	Description	Item	Description
1	Straps	5	Cardboard sleeve
2	Printed manuals and quick guides, manuals CD and multilingual residual voltage warning stickers	6...7	Cushions
3	Cardboard cover	8	Drive with factory installed options
4	Flange mounting kit	9	Cardboard tray

To unpack:

- Cut the straps (1).
- Remove the top cardboard cover (3), lift the flange mounting kit (4), and remove the cushions (6...7).
- Lift the cardboard sleeve (5).
- Lift the drive (8).



Frames R6 to R9

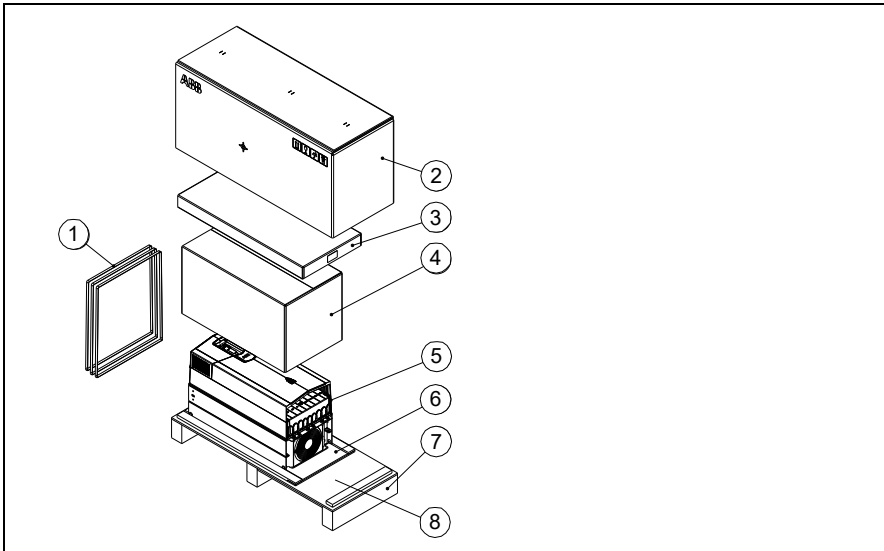

Item	Description	Item	Description
1	Straps	5	Drive with factory installed options
2	Cardboard cover	6	Pallet stopper
3	Flange mounting kit	7	Pallet tray
4	Cardboard sleeve	8	Printed manuals and quick guides, manuals CD and multilingual residual voltage warning stickers

To unpack:

- Cut the straps (1).
- Remove the cardboard cover (2).
- Lift the flange mounting kit (3).
- Remove the cardboard sleeve (4).
- Attach lifting hooks to the lifting eyes of the drive (5). Lift the drive with a hoist.

■ Flange mounting kit package contents

The illustrations show the layout of the flange mounting kit packages. Examine that all items are present and there are no signs of damage.

Frames R1 to R3

1	Quick guide
2	Cable shelf
3	Top bracket
4	Grounding plate
5	Bottom bracket
6	Side brackets
7	Cardboard tray
8	Top cardboard cover
9	Option kit package label
10	Mounting template
11	Screw package: <ul style="list-style-type: none"> • M5 nut (4 pcs) • M6 nut (17 pcs) * • M5×20 screw (4 pcs) • M6×25 screw (10 pcs) • M5×25 T20 screw (1 pcs) • M5×50 T20 (2 pcs)
12	Sealing plug
13	Sealing plate
14	Tightening brackets
15	Bottom U-bracket
16	Top U-bracket

* The delivery does not include the Rivet or Kalei nuts for the M6 screws.



Frames R4 to R5

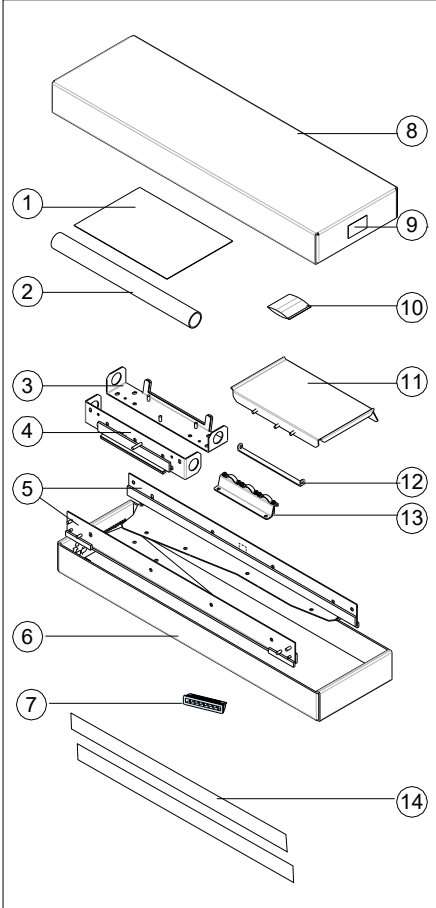

1	Quick guide
2	Mounting template
3	Bottom bracket
4	Top bracket
5	Side brackets
6	Cardboard tray
7	Sealing plug
8	Top cardboard cover
9	Option kit package label
10	Screw package: <ul style="list-style-type: none"> • M6 nut (14 pcs) * • M6×20 screw (2 pcs) • M6×25 screw (13 pcs) • M6×10 T30 screw (R4: 6 pcs; R5: 8 pcs)
11	Hood (required for UL Type 12)
12	Tightening bracket
13	Cable shelf
14	Sealing tapes

* The delivery does not include the Rivet or Kalei nuts for the M6 screws.

Frames R6 to R9

1	Quick guide
2	Mounting template
3	Top bracket
4	Bottom bracket
5	Side brackets
6	Top cardboard cover
7	Option kit package label
8	Screw package: <ul style="list-style-type: none"> • M6 nut (11 pcs) * • M6×10 T30 (12 pcs) • M6×25 T25 (R6...R8: 16 pcs, R9: 18 pcs)
9	Hood (required for UL Type 12)
10	Cardboard tray

* The delivery does not include the Rivet or Kalei nuts for the M6 screws.



■ Mounting template

The flange mounting kit package includes a template in actual size for drilling the mounting holes and cutting the holes in the mounting plate.

An example template is shown below.

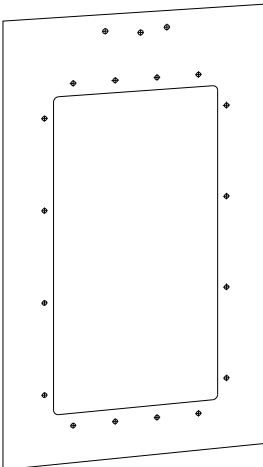

Installing the drive

■ Free space requirements

The flange-mounted drives can be installed side by side. Free space requirements above and below the drive are shown below.

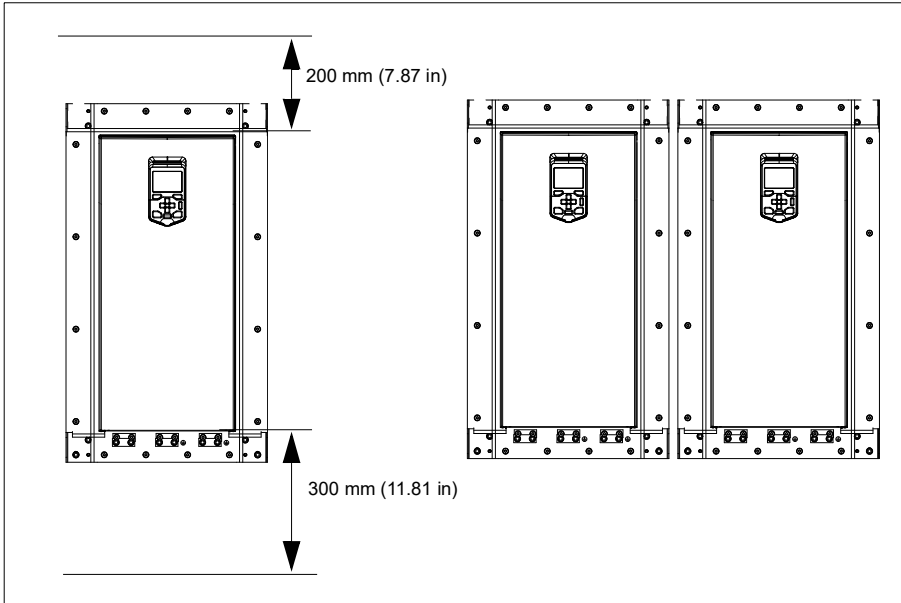

■ Installing drives above one another

Make sure that the outlet cooling air flows away from the drive above.

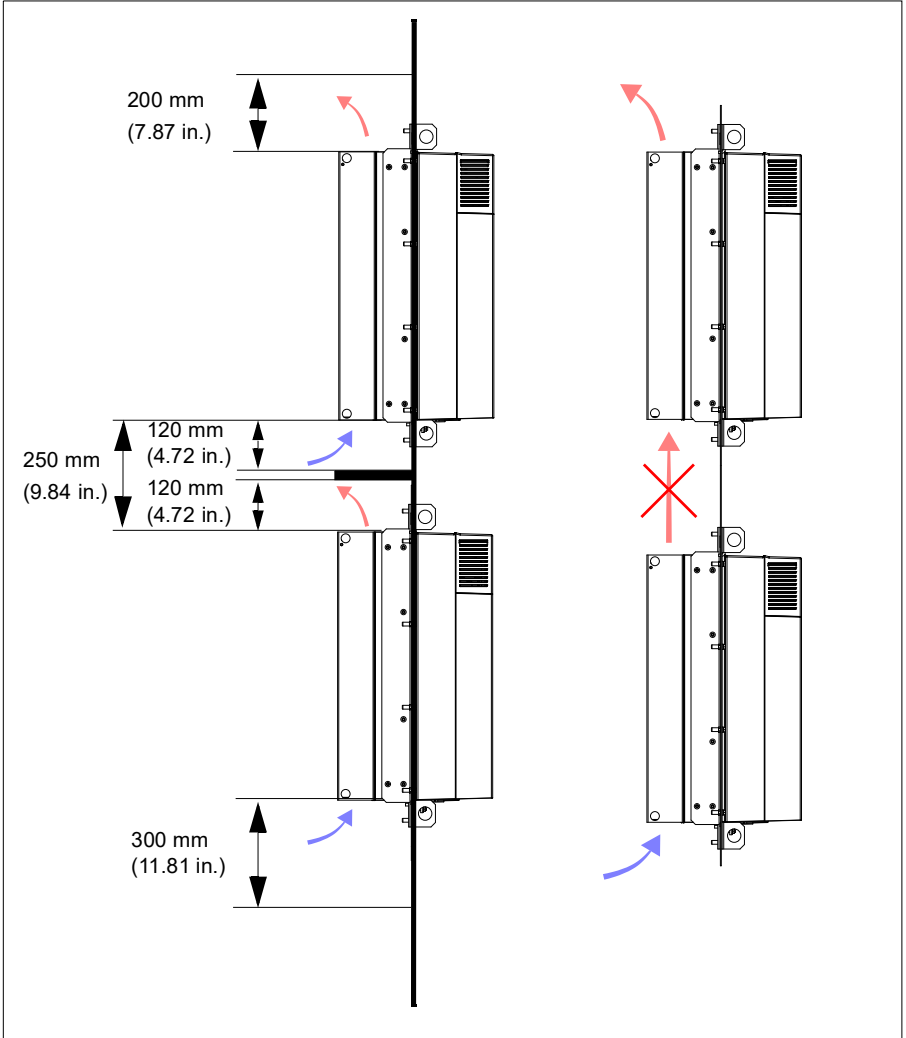

Installation procedure

■ Frames R1 to R3

1. To remove the fan assembly, push the retaining clip with a flat screwdriver. Lift the assembly up.

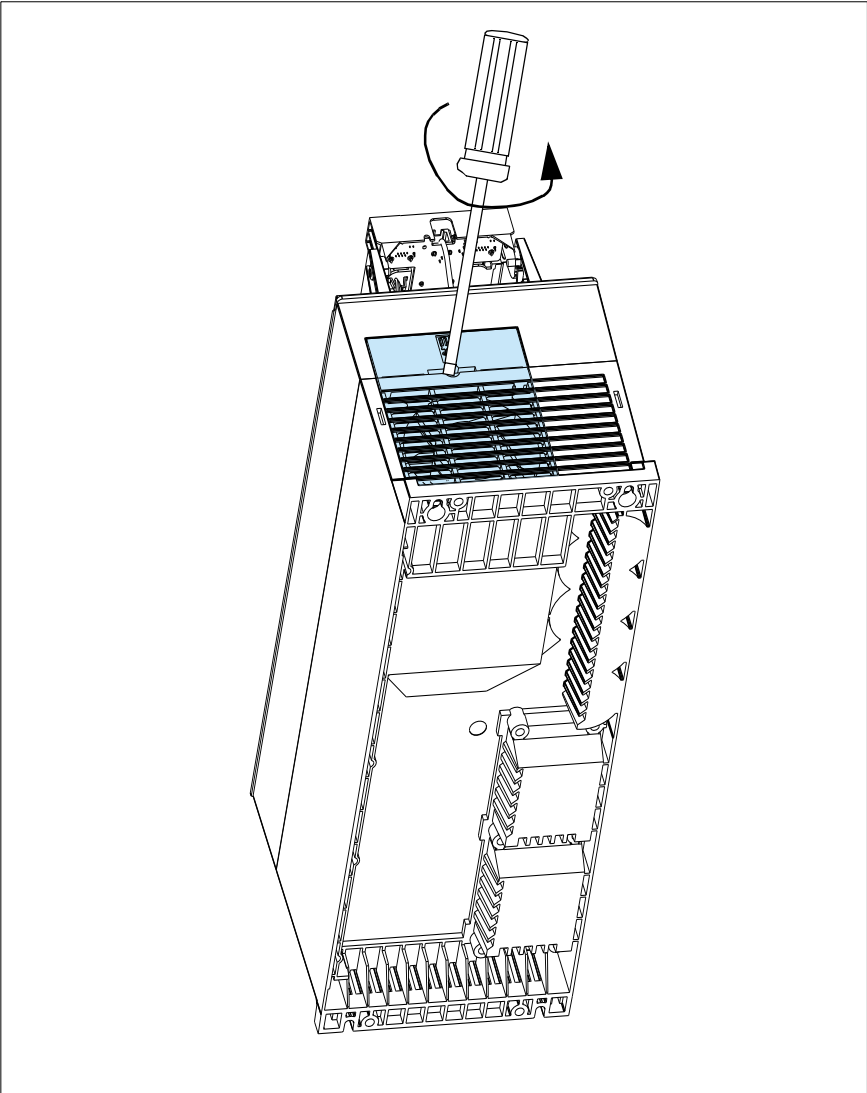

2. Insert the sealing plug to the hole shown in the figure.

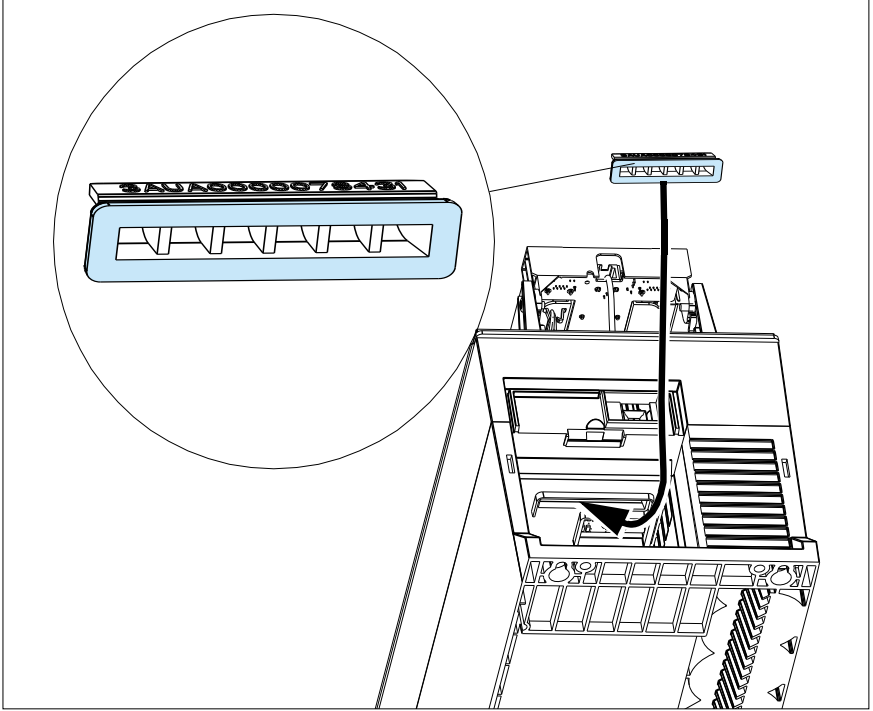

3. Reinstall the fan assembly in reverse order.

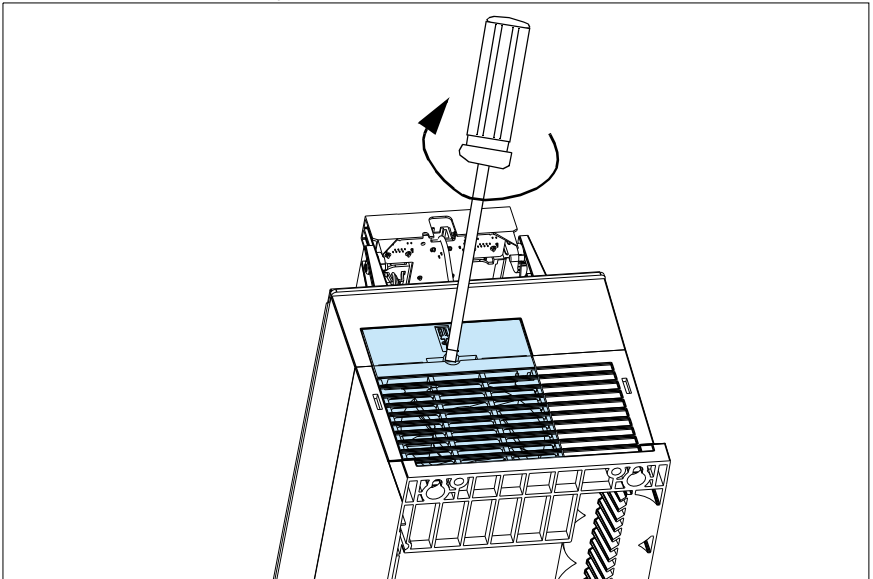

24 *Mechanical installation*

4. Attach the top and bottom U-brackets to the drive.

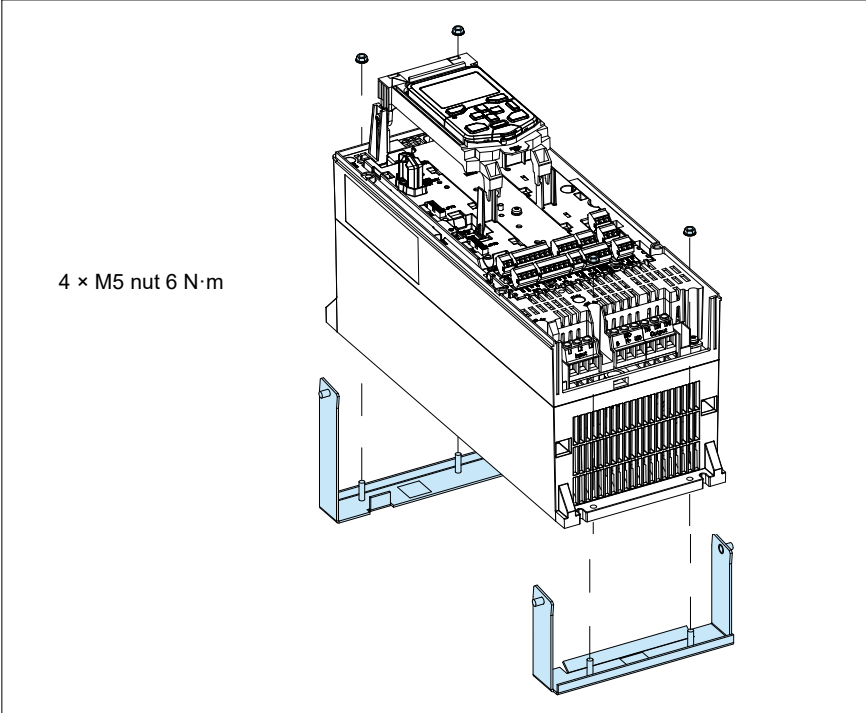

5. First attach the side brackets (a) to the top and bottom U-brackets with four M6 nuts. Then, attach the tightening brackets (b) to the both ends with four M5×20 screws. Last attach the sealing plate (c) to the bottom of the drive with two M5×50 screws T20.

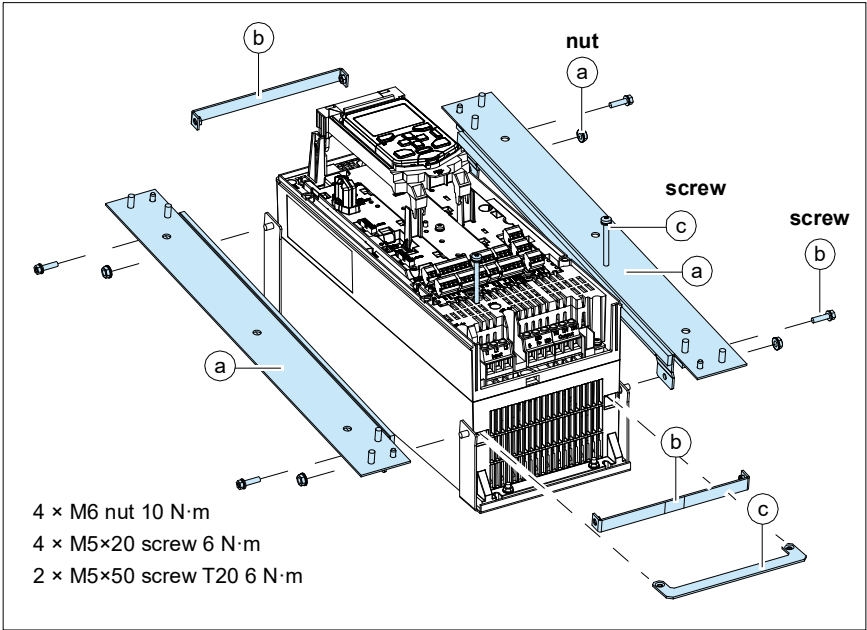

6. Attach the top and bottom brackets to the side brackets.

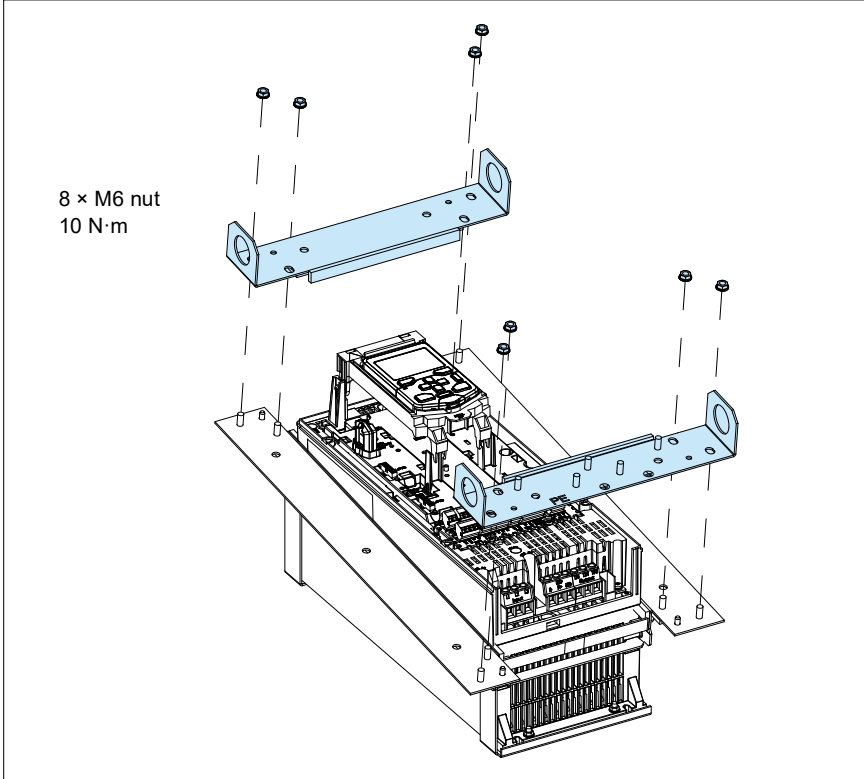

7. Push the grounding plate (d) onto the alignment pins of the bottom bracket and attach it to the drive with one M5×25 screw T20 and three M6 nuts.

Then attach the cable shelf (e) to the bottom bracket with two M6 nuts.

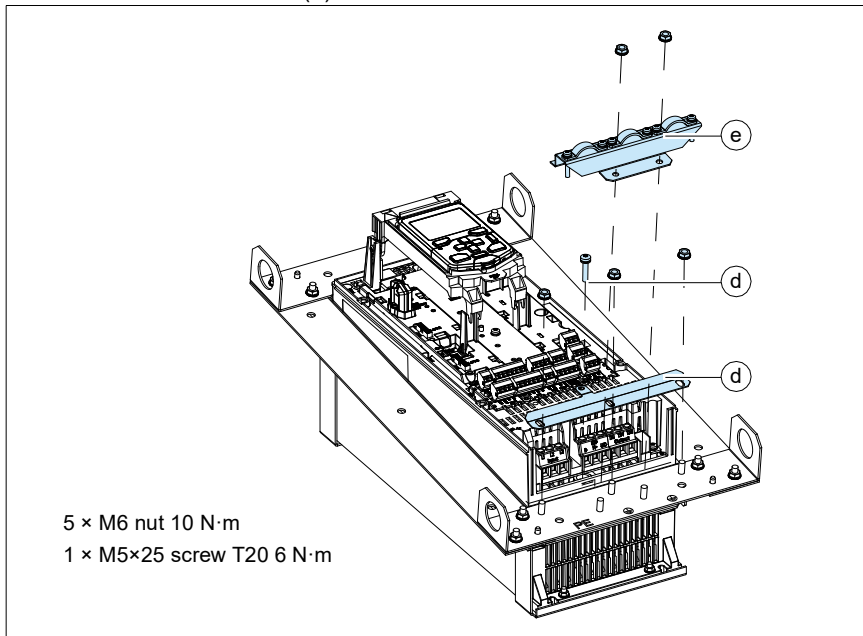

- See chapter [Dimension drawings](#) for the dimensions of the flange and the required opening in the mounting plate. Attach the mounting template from the flange mounting kit package onto the mounting plate.

Make the opening and drill the holes for the mounting screws. Consider the hole size for the Rivet or Kalei nuts (not included in the delivery). Remove the mounting template.

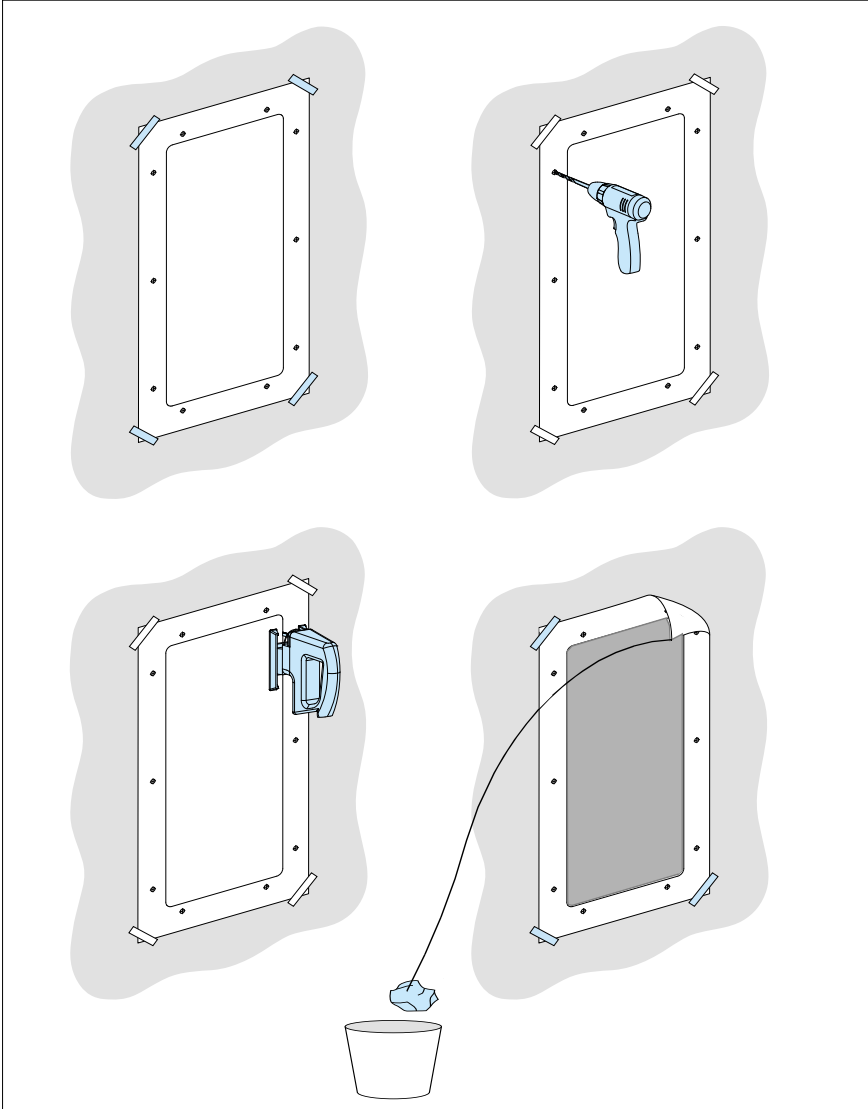

9. Attach chains to the drive lifting holes and lift the drive with a lifting device onto the opening in the mounting plate.

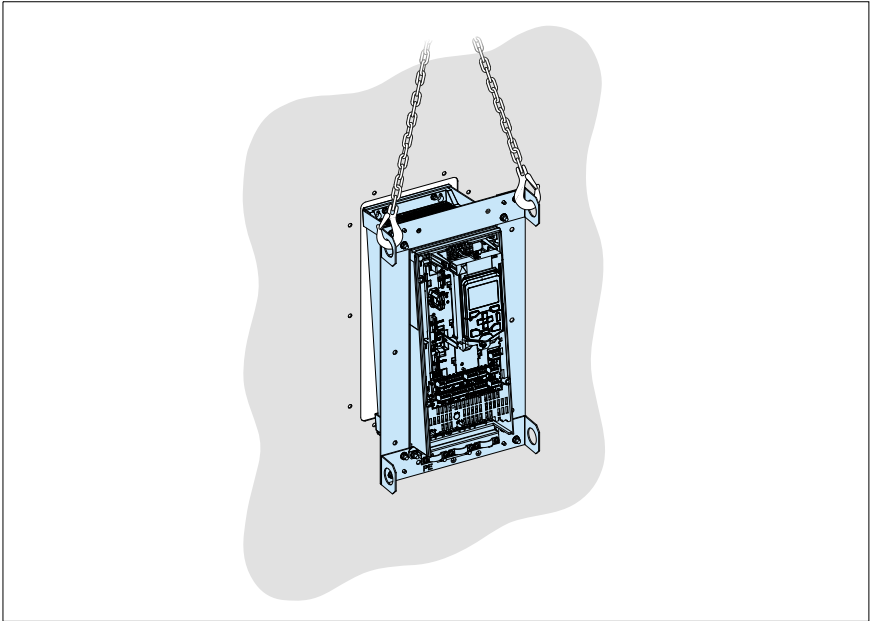

10. Attach the bottom bracket with one screw.

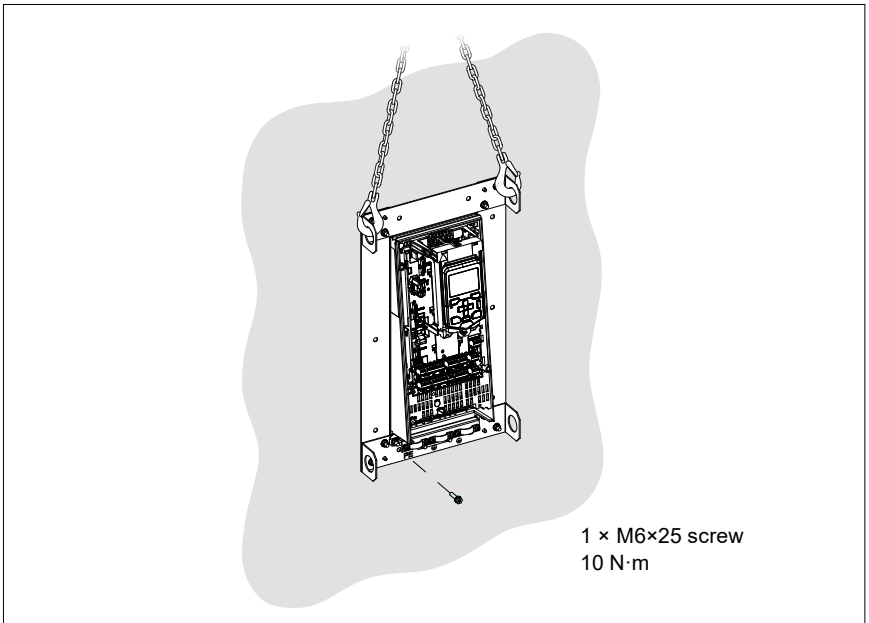

11. Attach the top bracket with one screw.

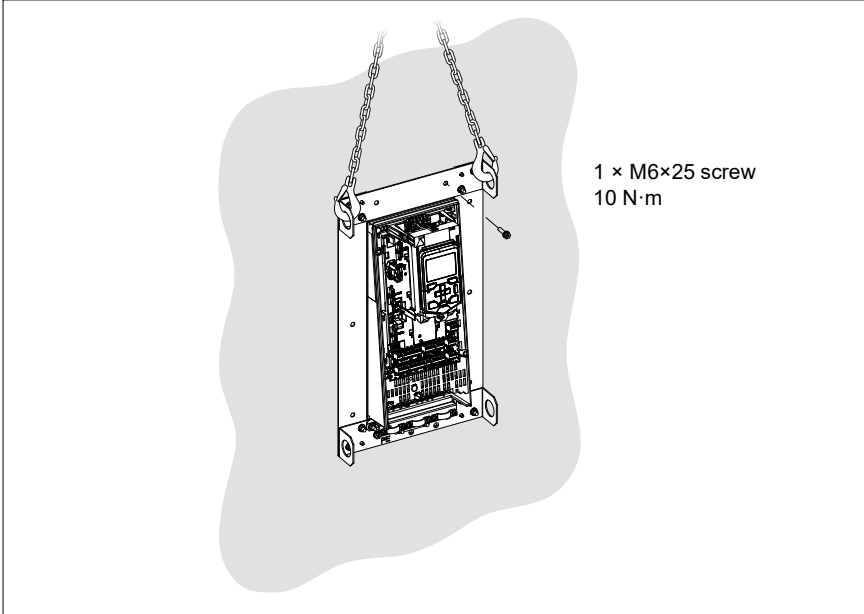

12. Attach the rest of the mounting screws. Remove the chains.

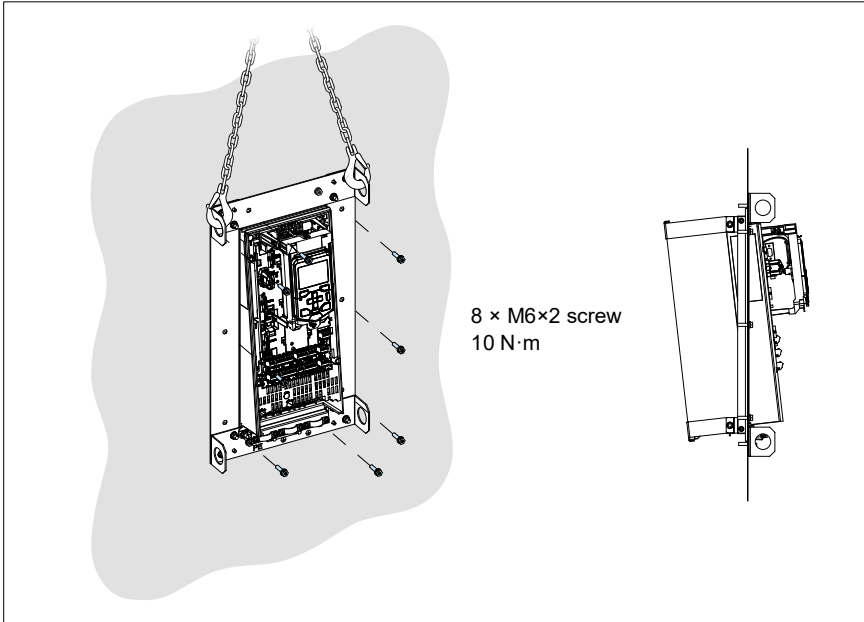

■ **Frames R4 to R5**

1. To remove the fan assembly, lift the fan mounting plate up from the front edge. Unplug the fan power supply wires. Lift the assembly off.

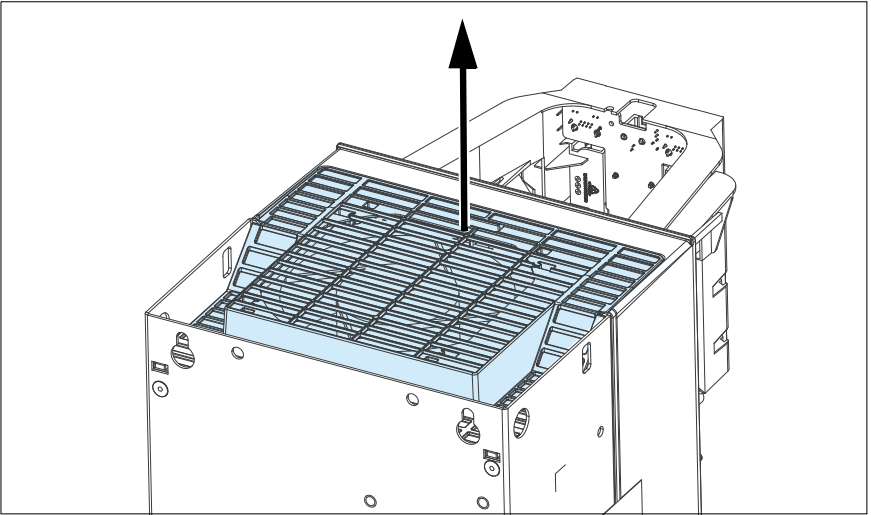

2. Insert the sealing plug to the hole shown in the figure.

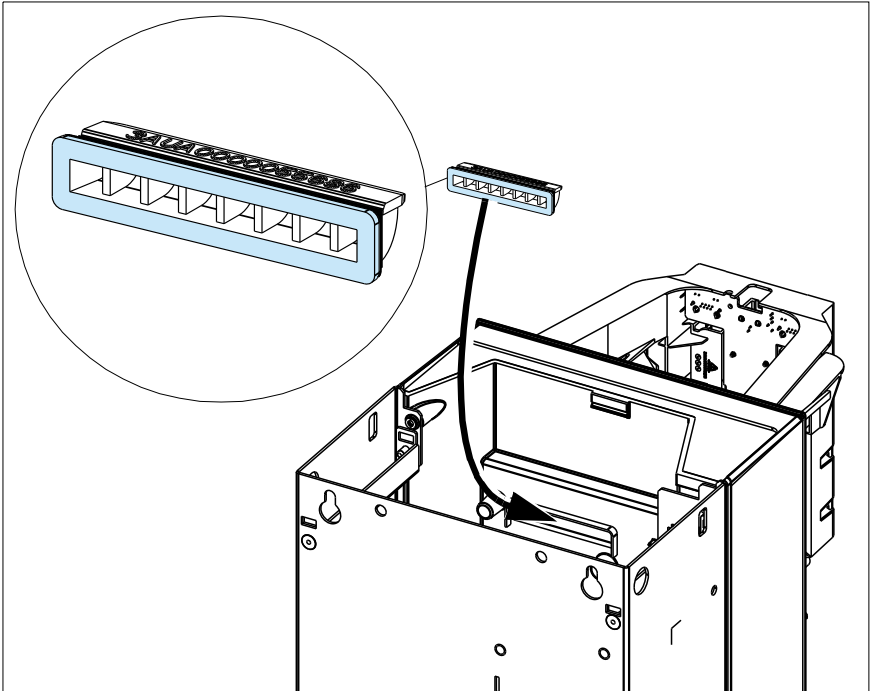

3. Reinstall the fan assembly in reverse order.

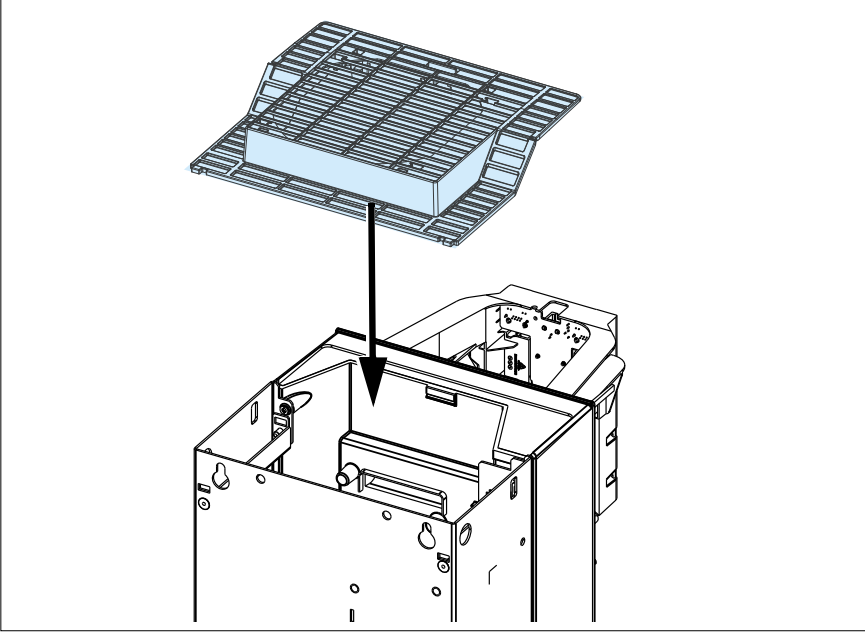

4. Attach the sealing tapes on **both** sides of the drive.

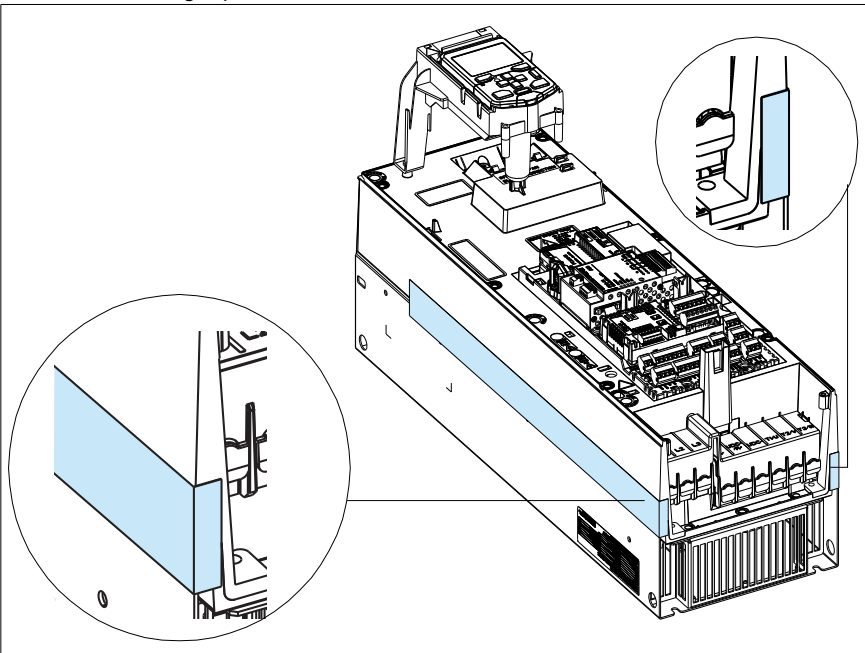

5. Attach the side brackets to the drive. Note that R4 has 6 screws for attaching the side brackets while R5 has 8 screws.

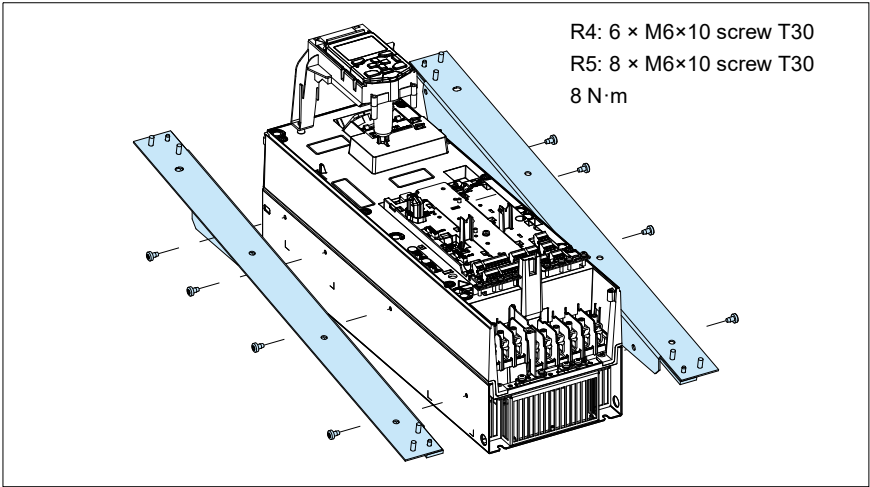

6. Attach the bottom bracket and the tightening bracket to the side brackets.

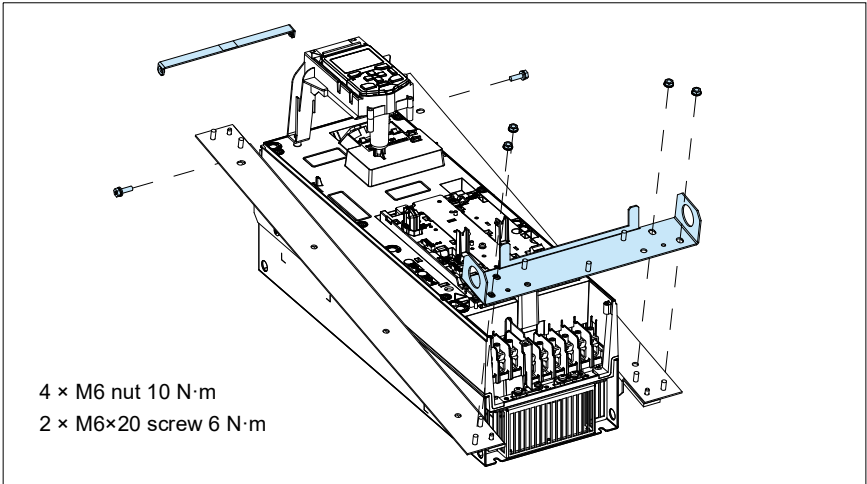

7. Attach the top bracket to the side brackets.

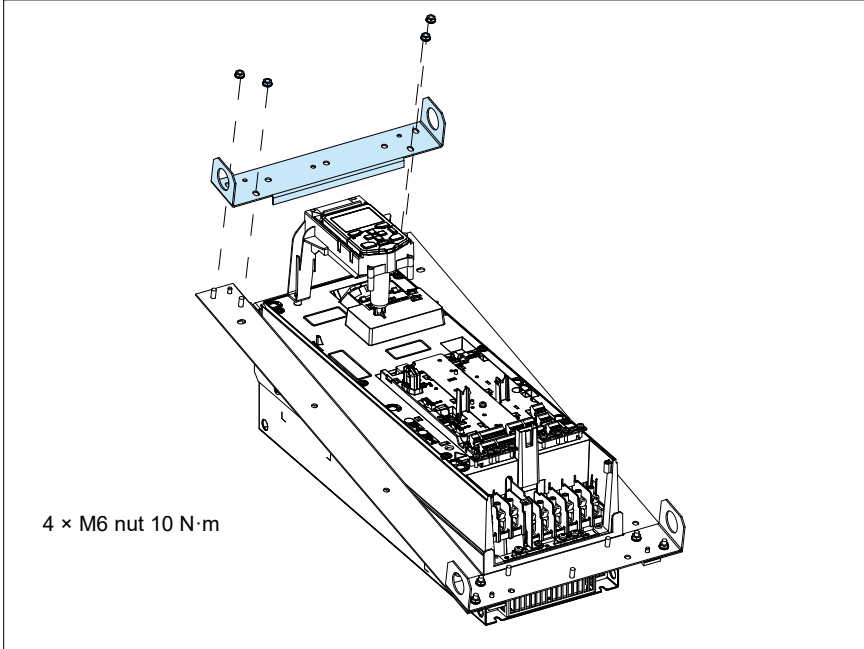

8. Attach the cable shelf to the bottom bracket.

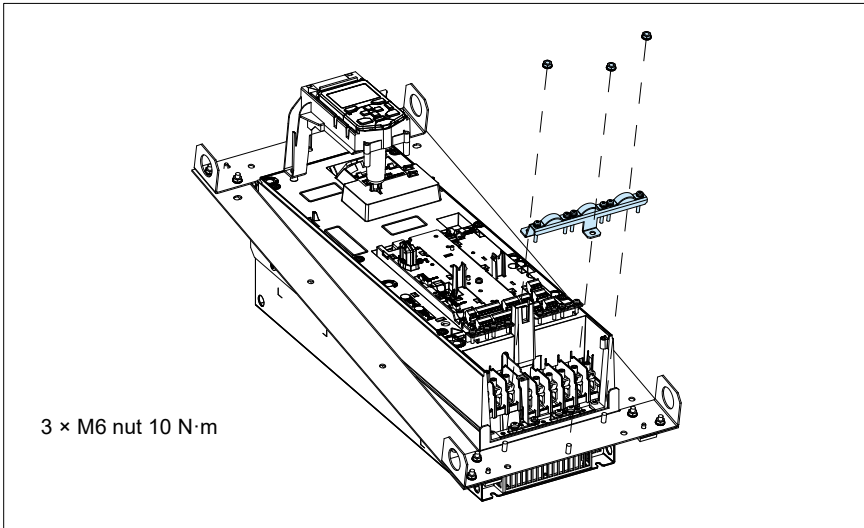

- See chapter *Dimension drawings* for the dimensions of the flange and the required opening in the mounting plate. Attach the mounting template from the flange mounting kit package onto the mounting plate.

Make the opening and drill the holes for the mounting screws. Consider the hole size for the Rivet or Kalei nuts (not included in the delivery). Remove the mounting template.

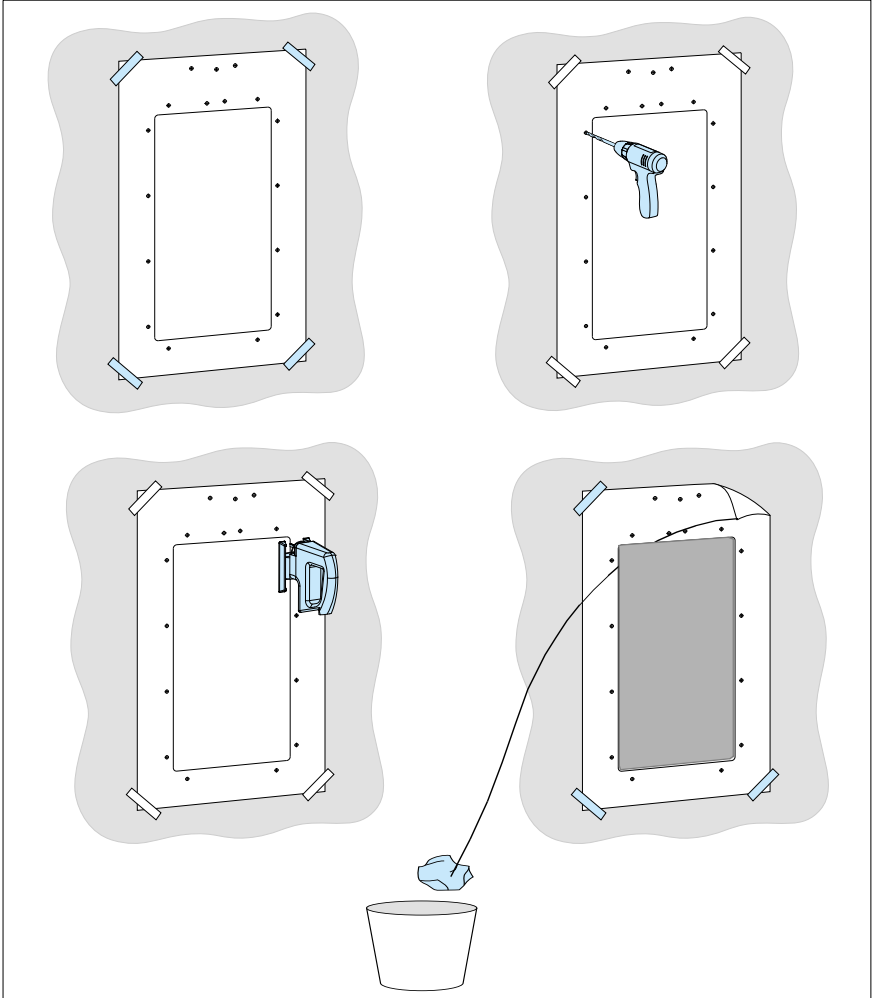

10. **UL Type 12 installation only:** Attach the hood to the cooling channel.

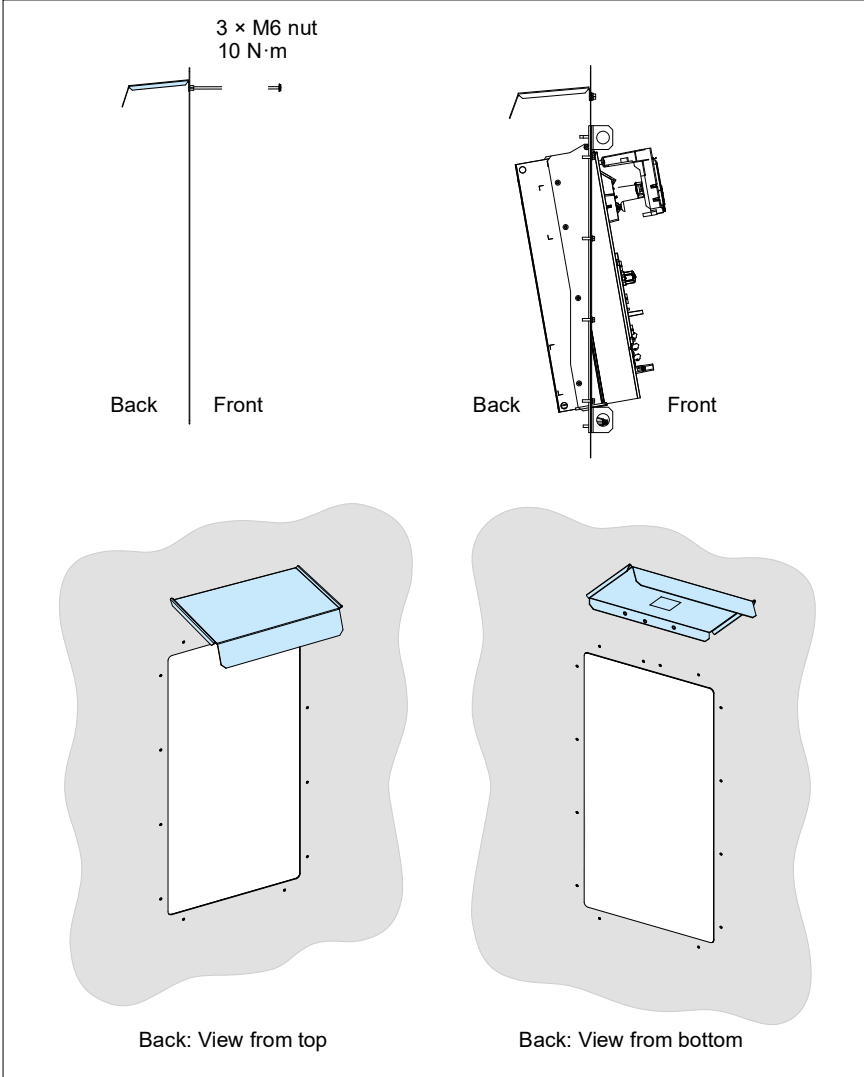

11. Attach chains to the lifting holes of the flange and lift the drive with a lifting device onto the opening in the mounting plate.

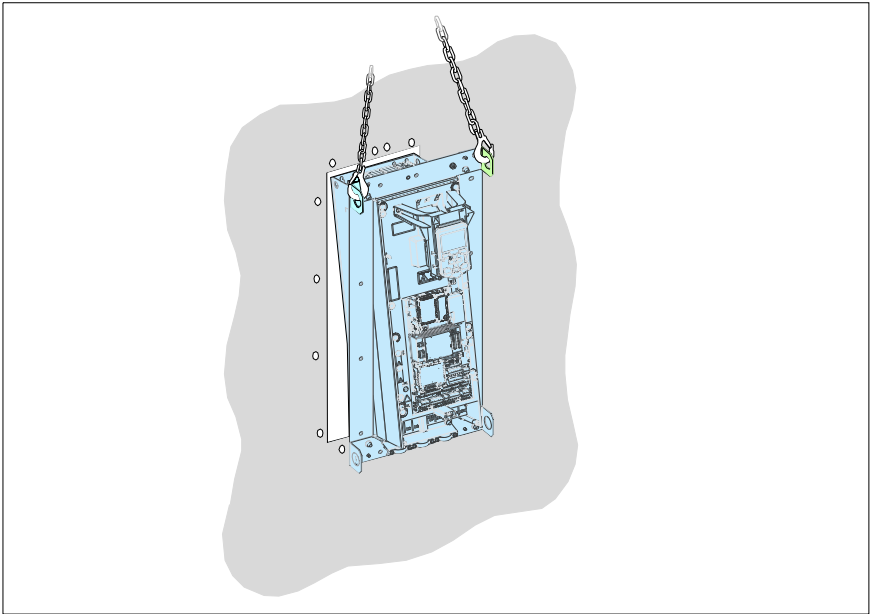

12. Attach the top bracket with one screw.

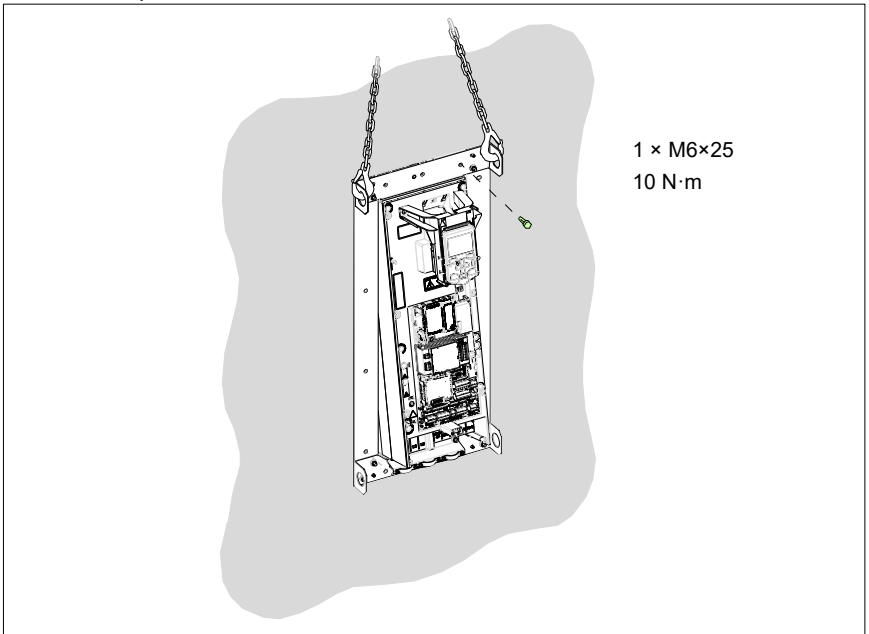

13. Attach the bottom bracket with one screw.

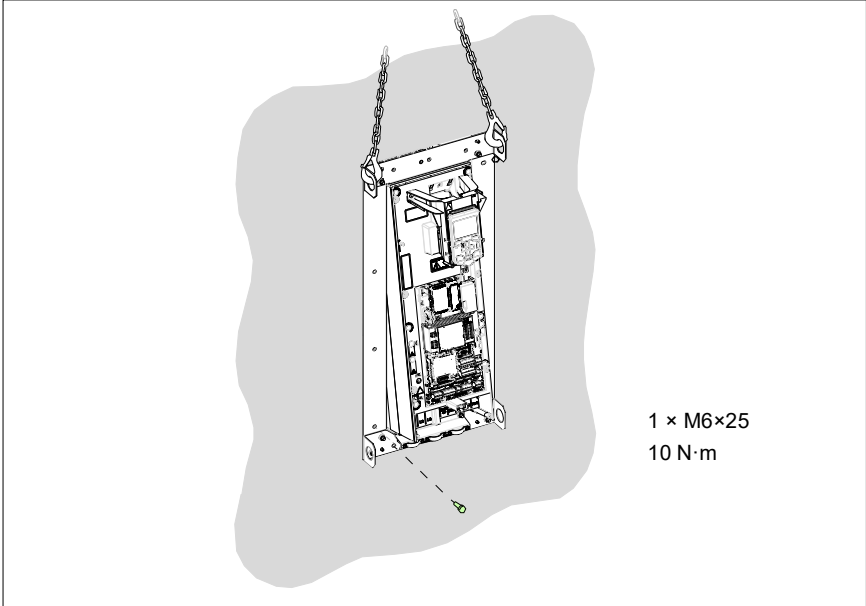

14. Attach the rest of the mounting screws. Remove the chains.

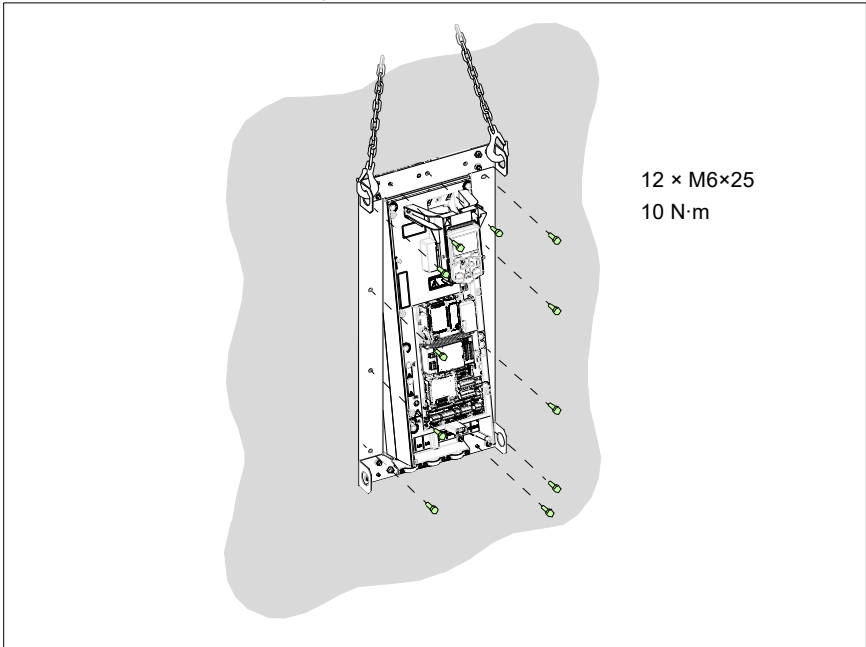

For instructions on installing an auxiliary cooling fan to drives with front cover on, see chapter *Maintenance* in the hardware manual.



■ Frames R6 to R9

1. Attach the side brackets of the flange to the drive.

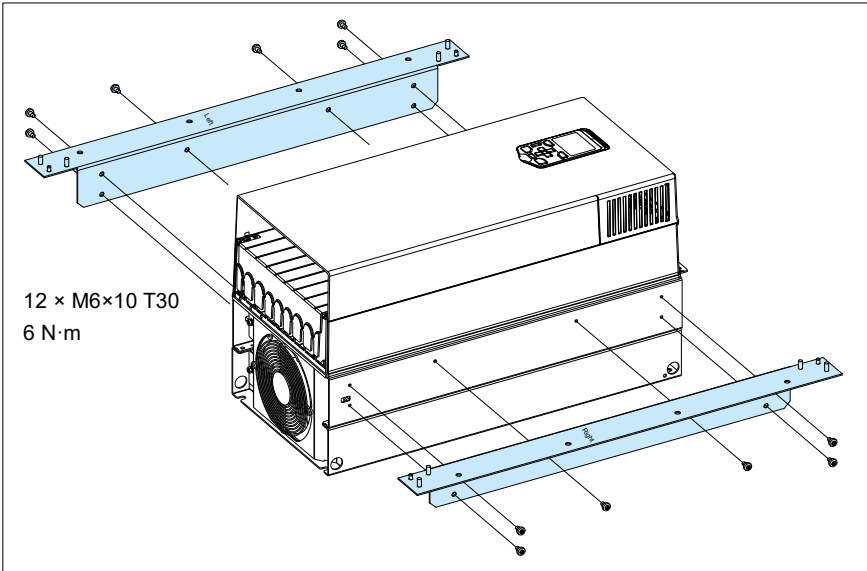

2. Attach the top and bottom brackets.

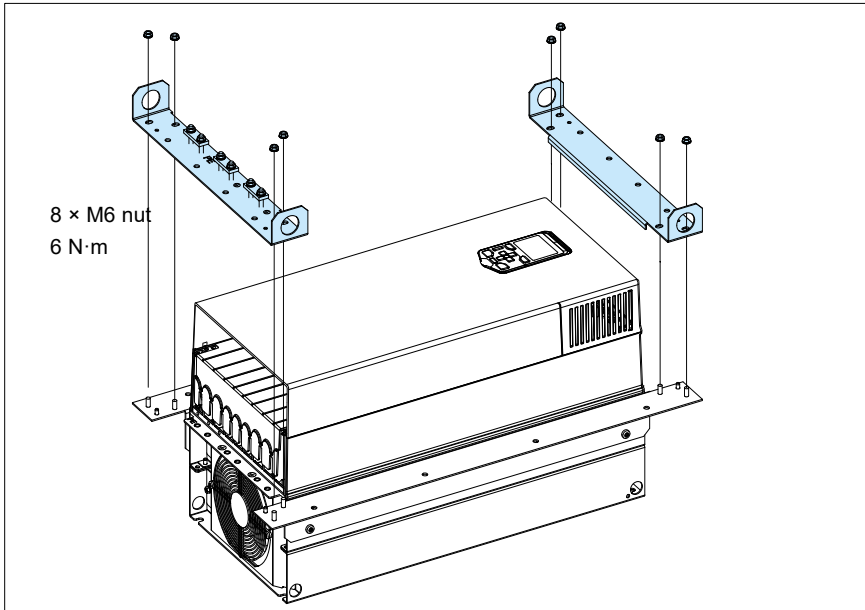

- See chapter *Dimension drawings* for the dimensions of the flange and the required opening in the mounting plate. Attach the mounting template from the flange mounting kit package onto the mounting plate.

Make the opening and drill the holes for the mounting screws. Consider the hole size for the Rivet or Kalei nuts (not included in the delivery). Remove the mounting template.

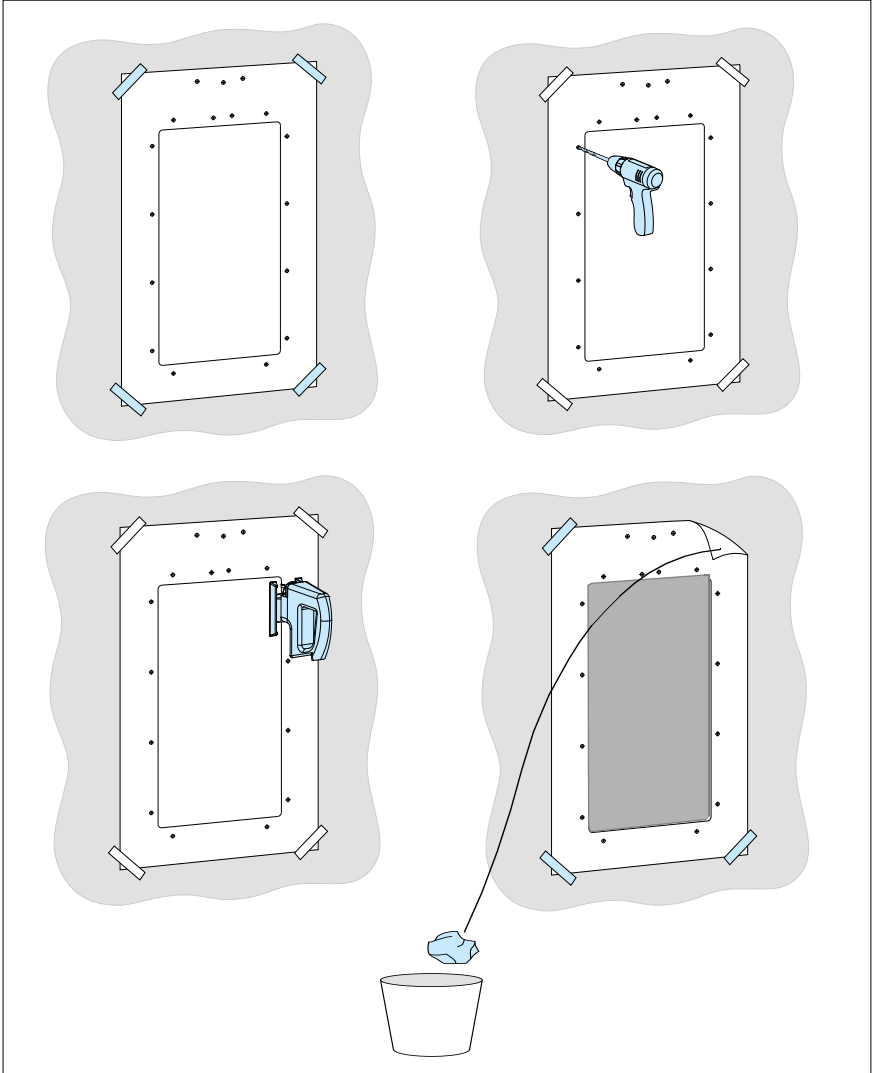

4. **UL Type 12 installation only:** Attach the hood to the cooling channel.

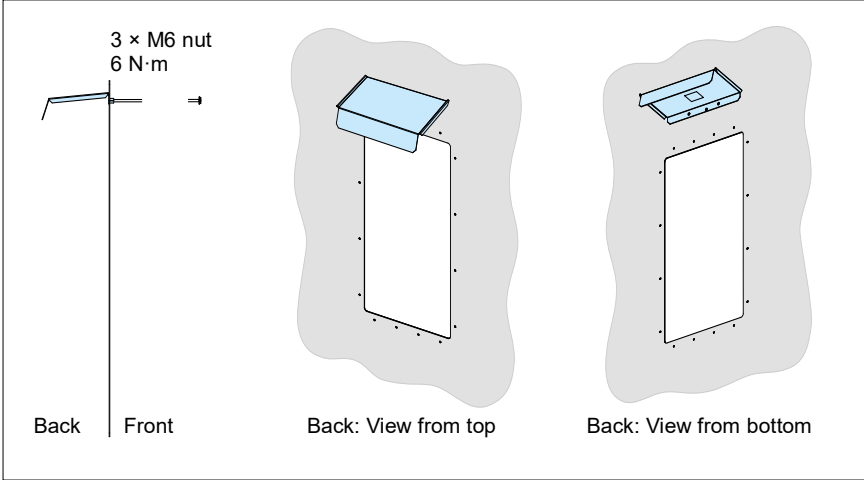

5. Attach chains to the lifting holes of the flange and lift the drive with a lifting device onto the opening in the mounting plate.

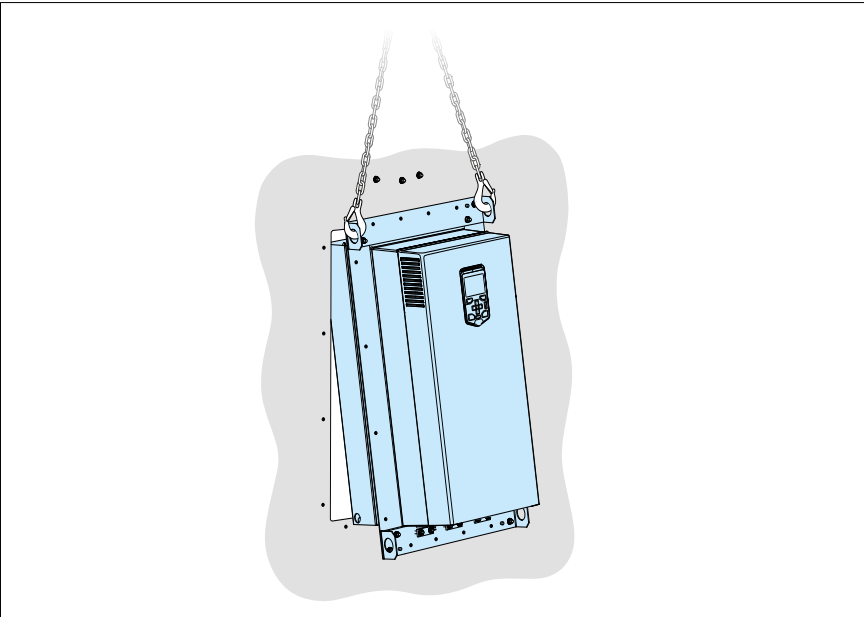

6. Attach the bottom bracket with one screw.

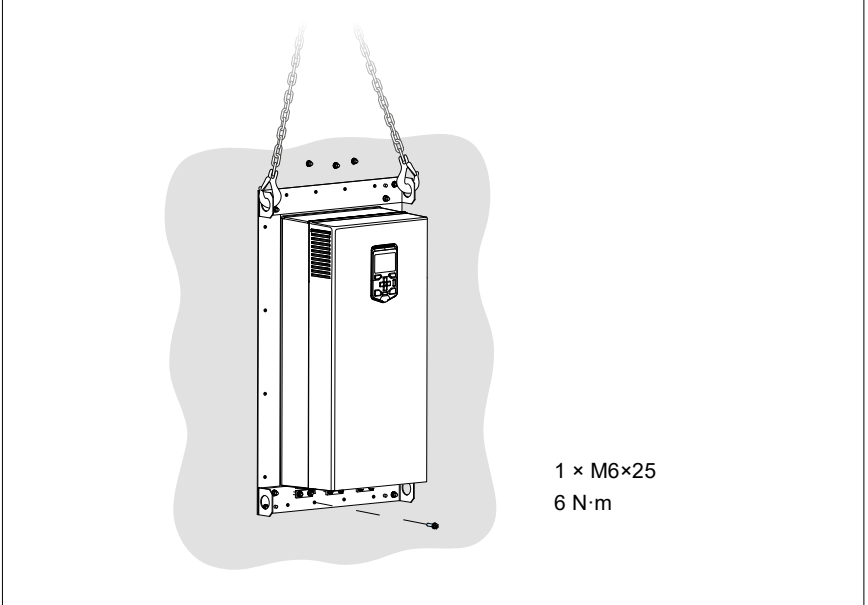

7. Attach the top bracket with one screw.

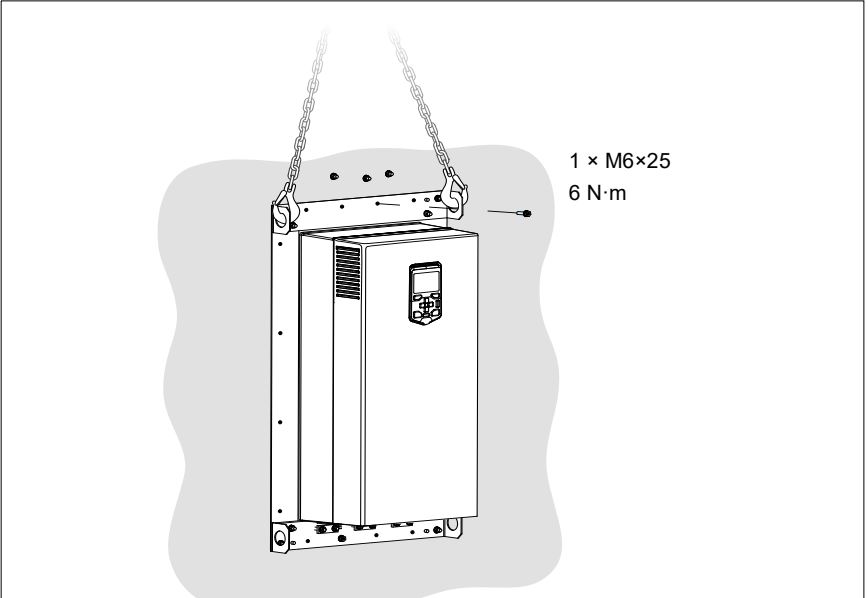

8. Attach the rest of the mounting screws. Remove the chains.

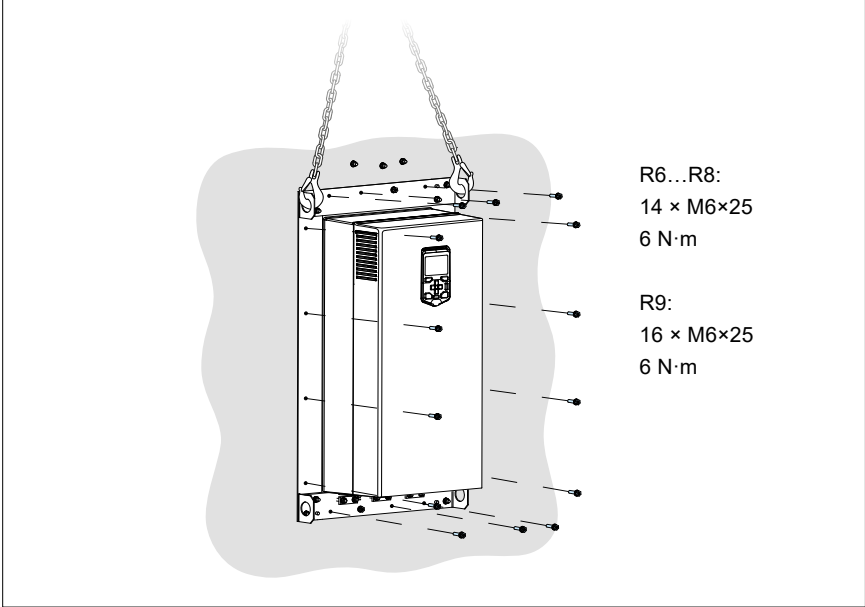



Dimension drawings

Contents of this chapter

This chapter contains the dimension drawings of the flange mounting kits and required openings in the mounting plate. For the dimensions of the drive, see the hardware manual.

Frame R1

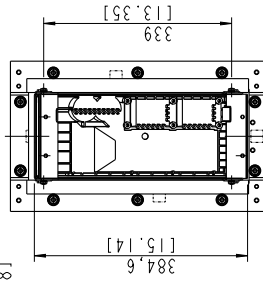
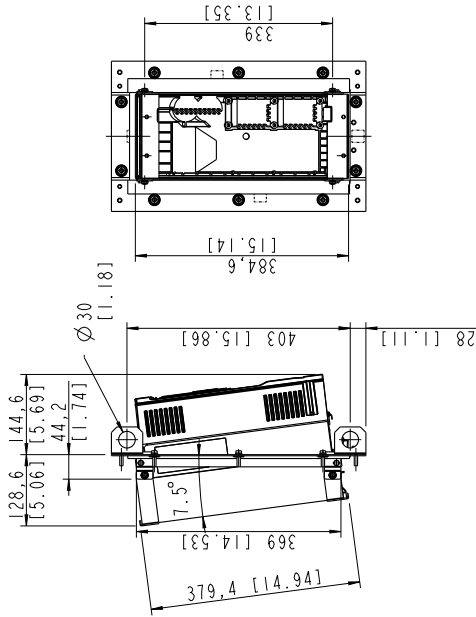
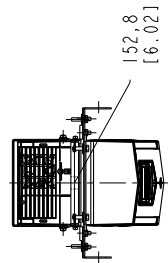
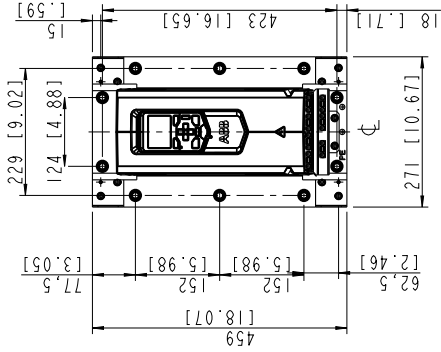
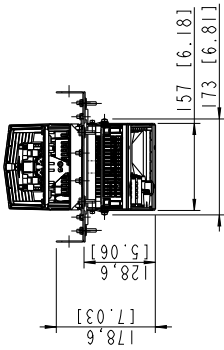

3AXD50000024531

■ Attaching points and opening dimensions

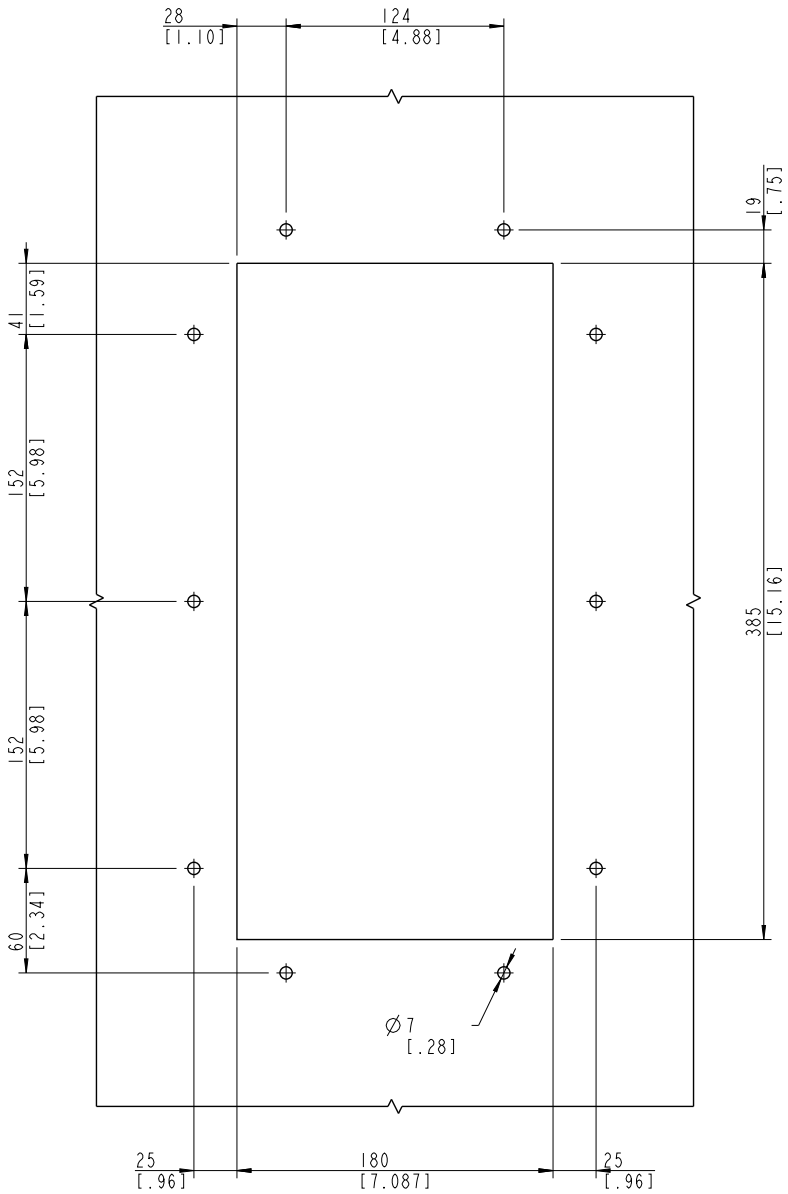

■ Attaching points and opening dimensions

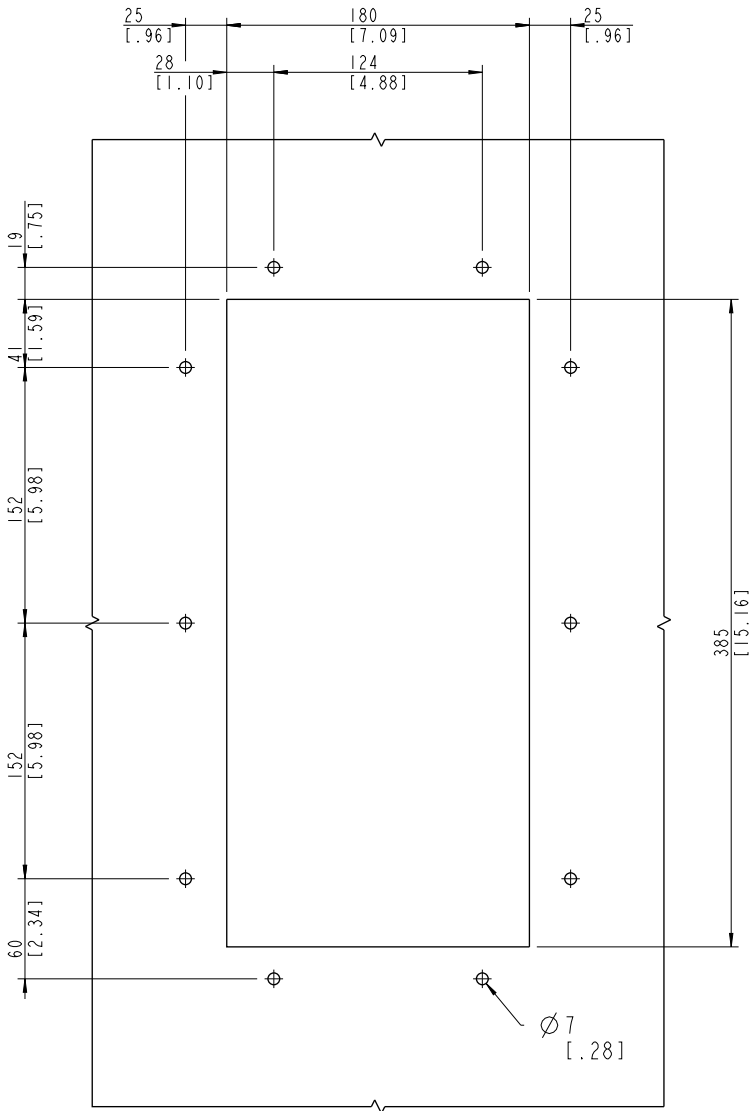

Frame R3

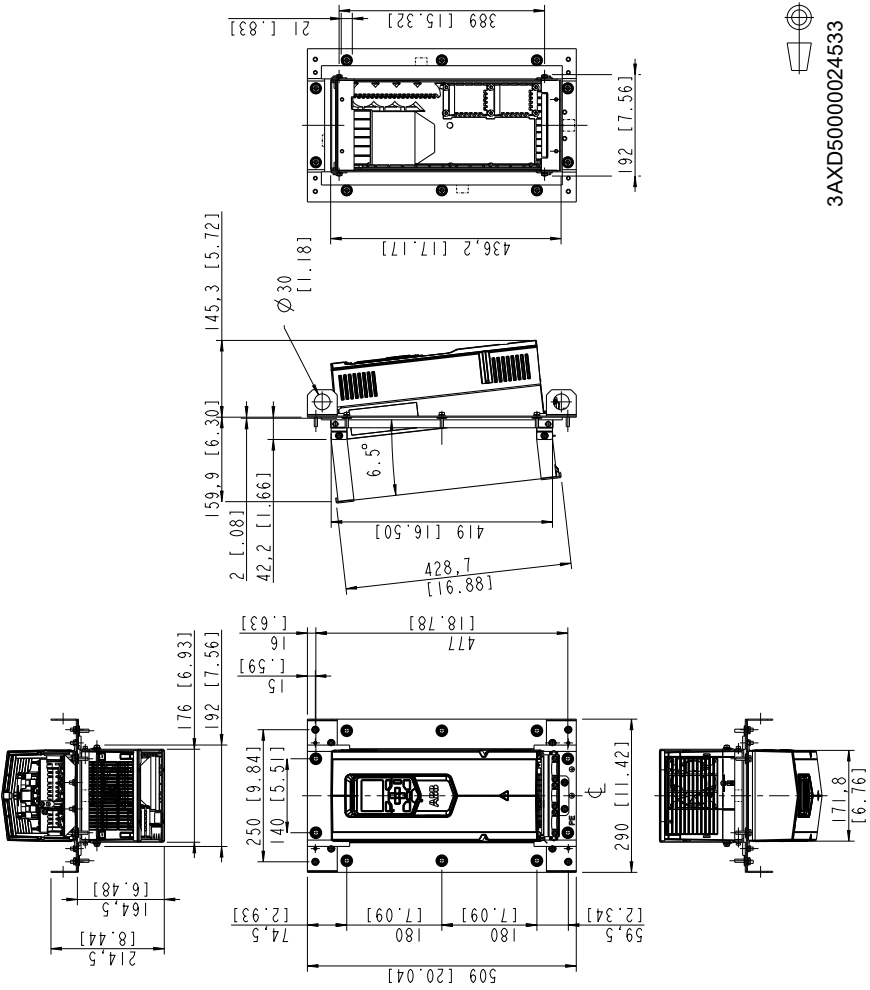

■ Attaching points and opening dimensions

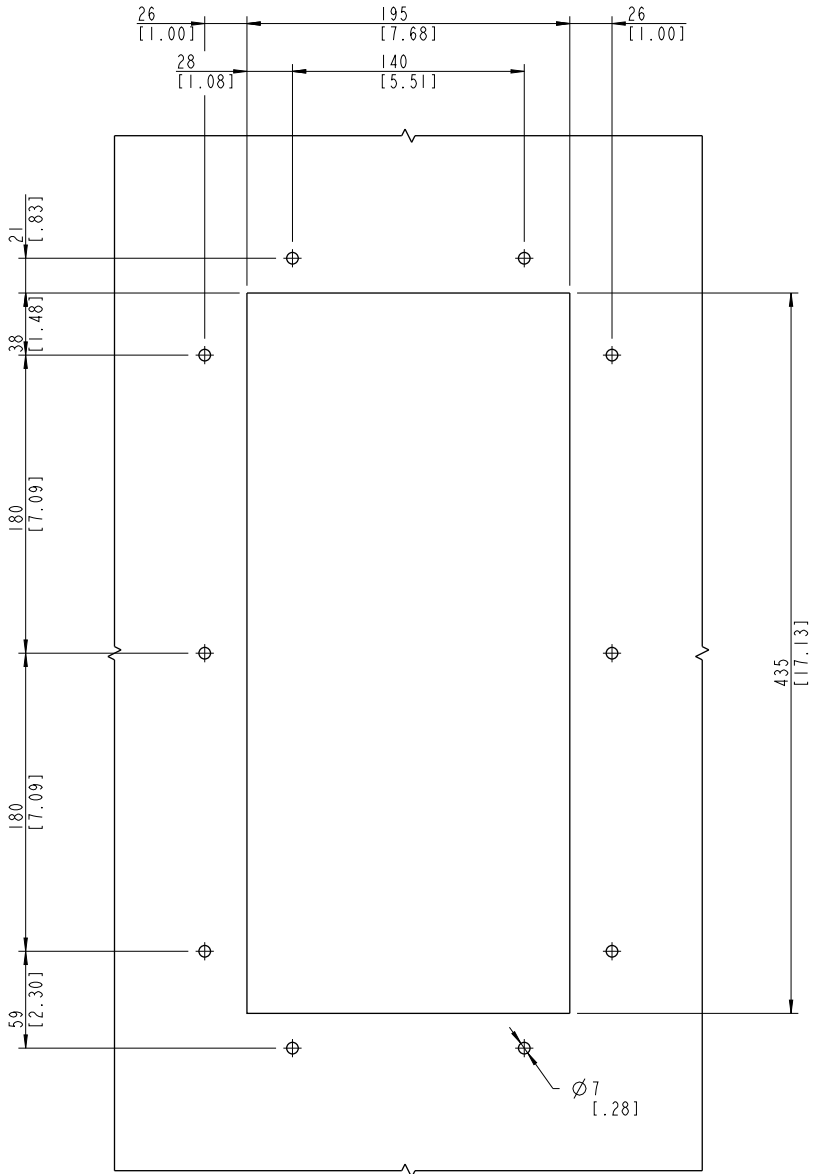

Frame R4

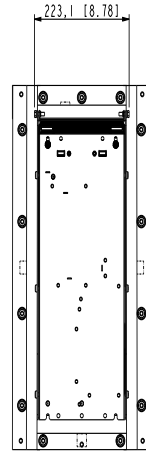
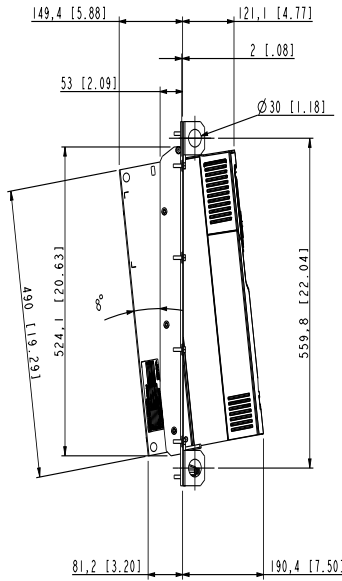
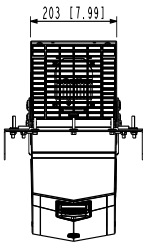
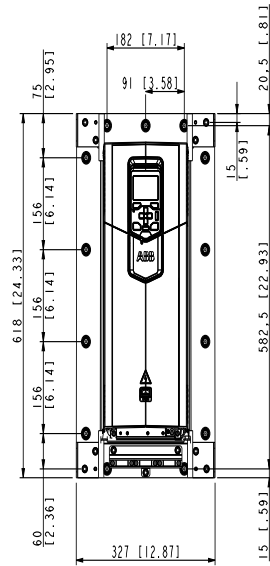
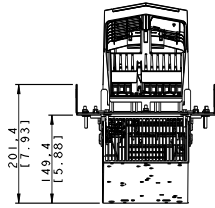

3AXD50000030170

Hood is needed for UL Type 12 installation only

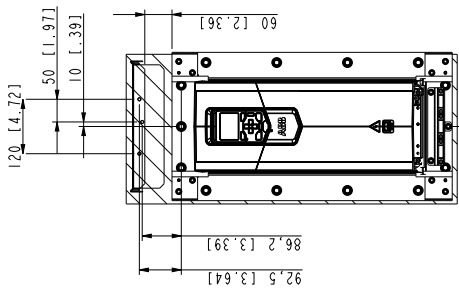
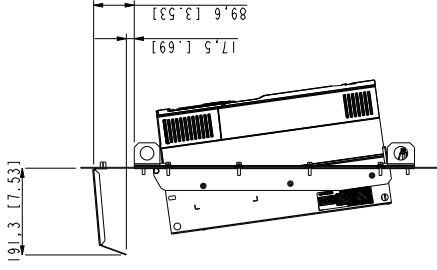
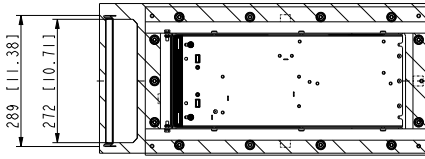

3AXD50000030170

■ Attaching points and opening dimensions

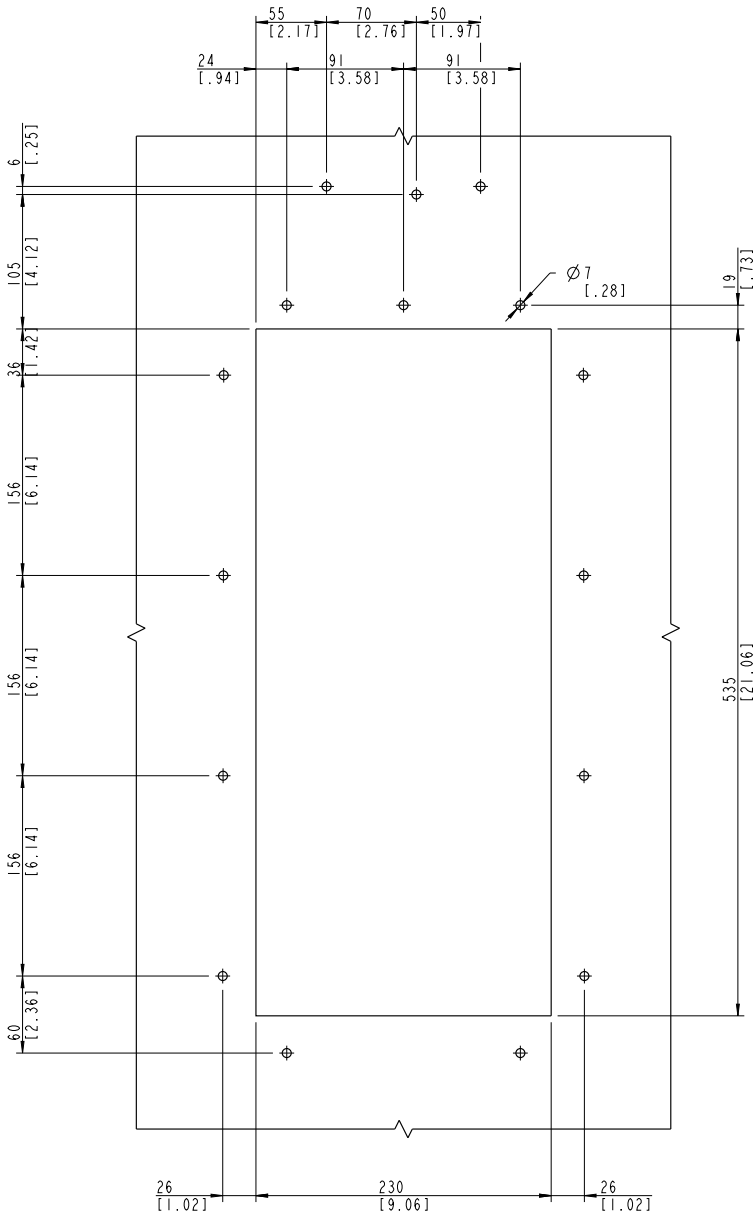

Frame R5

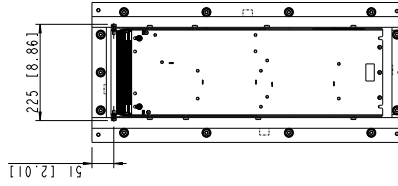
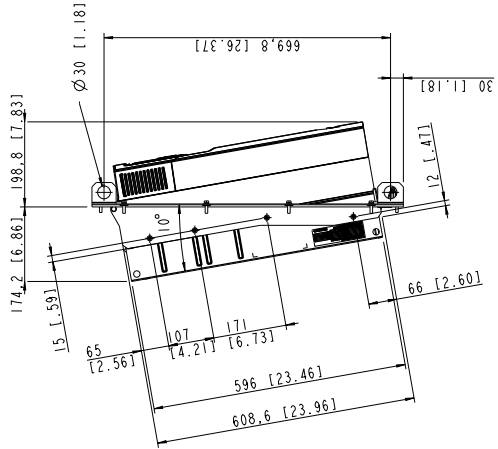
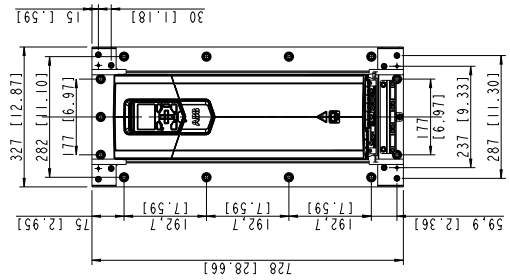
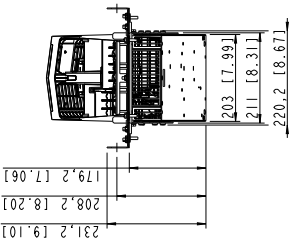

3AXD50000027088

Hood is needed for UL Type 12 installation only

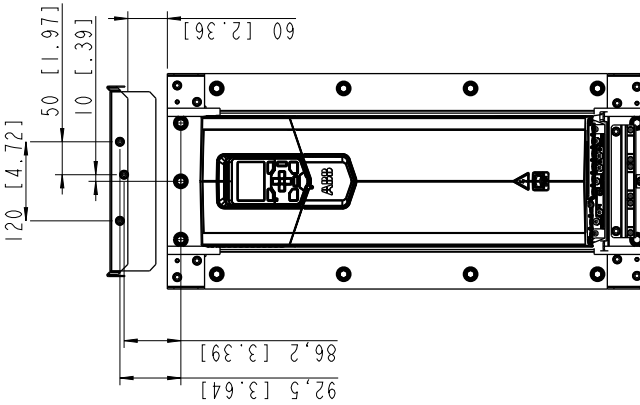
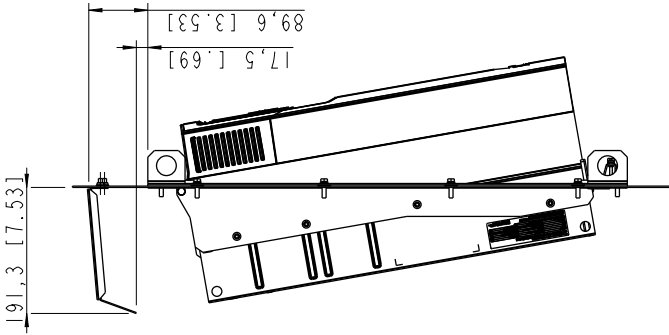
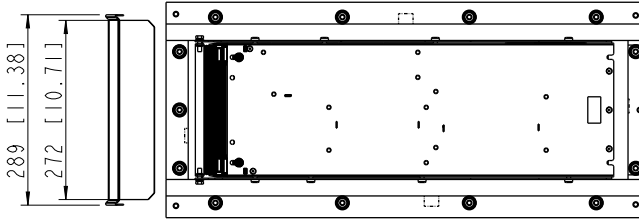

3AXD50000027088

■ Attaching points and opening dimensions

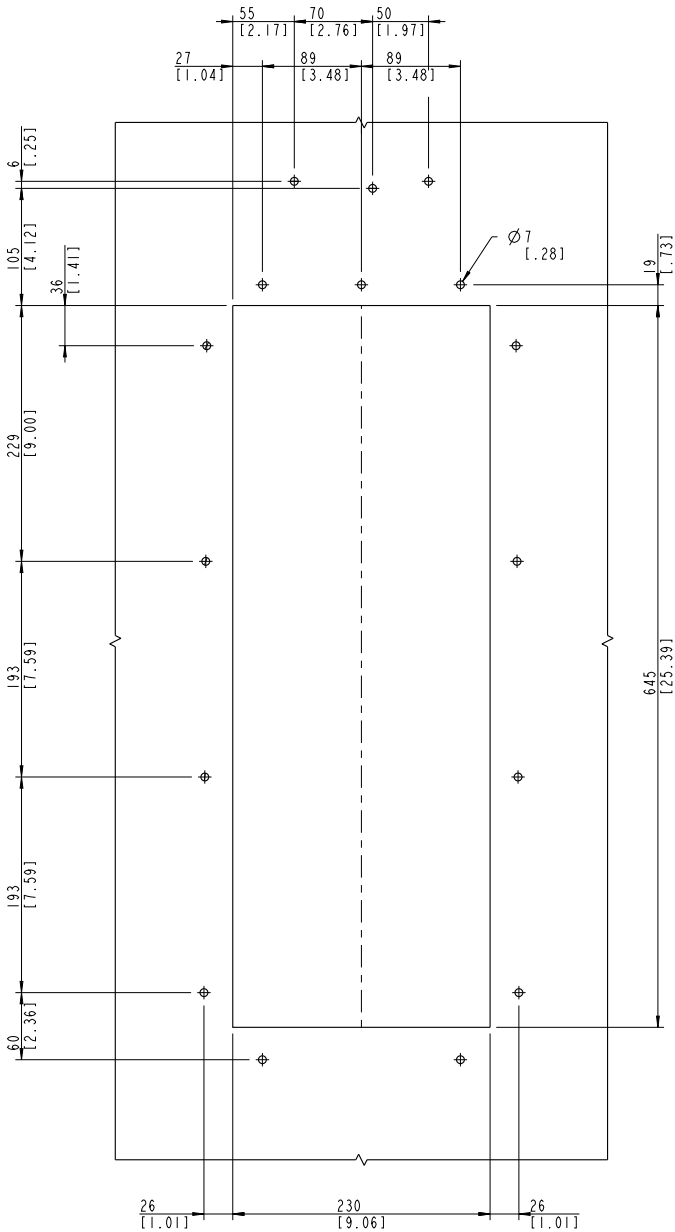

Frame R6

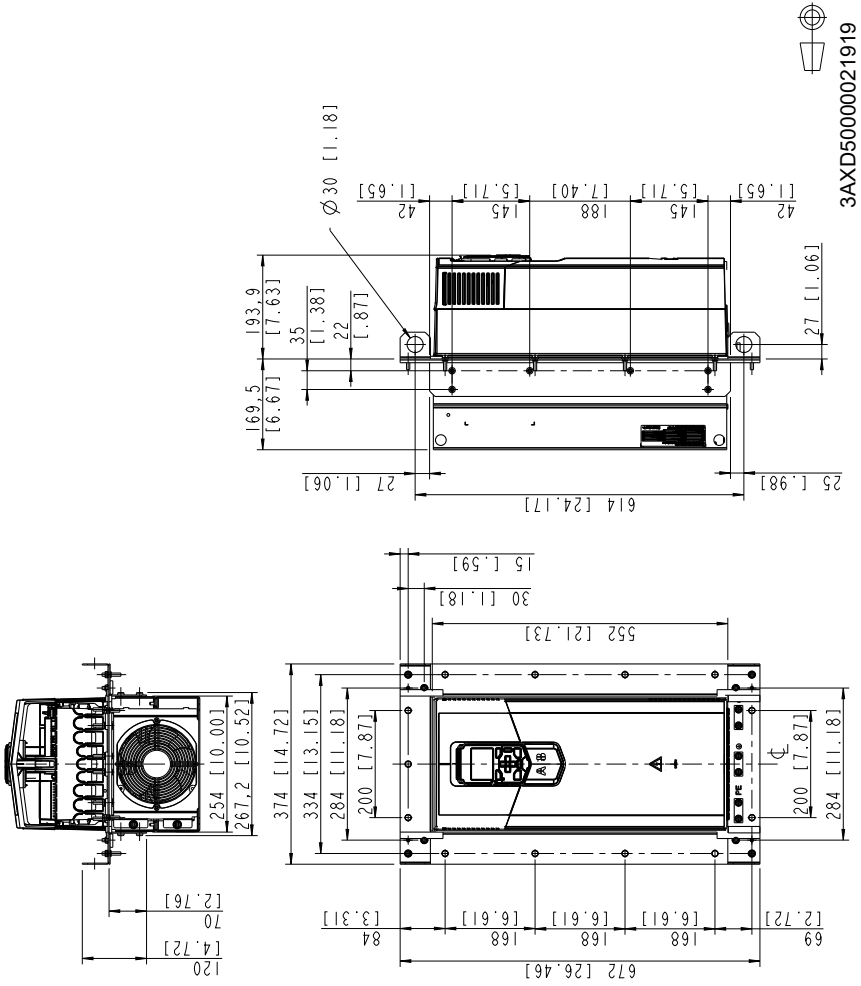

Hood is needed for UL Type 12 installation only

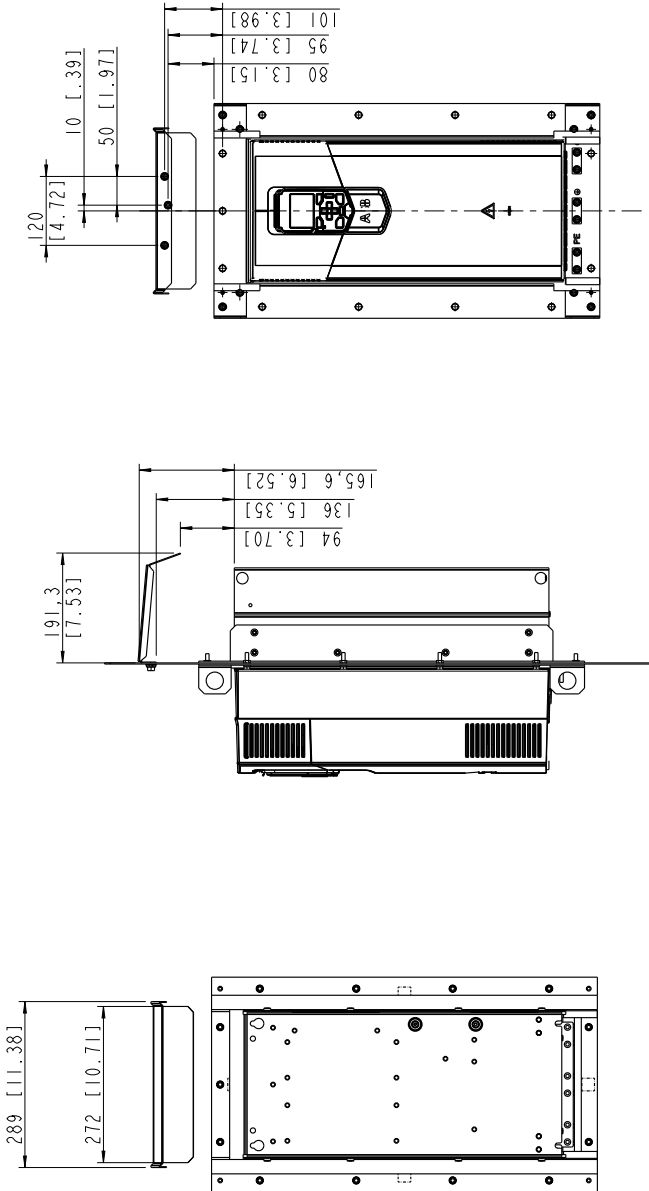

3AXD50000021919

■ Attaching points and opening dimensions

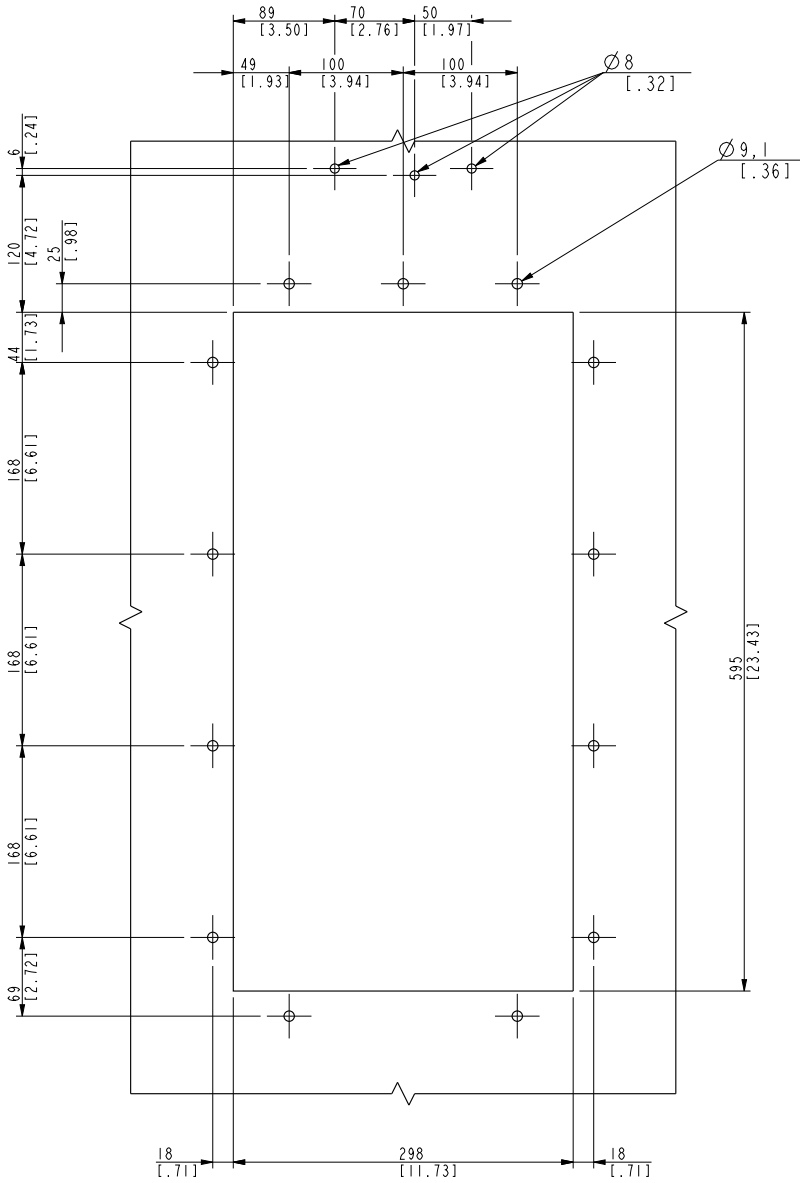

Frame R7

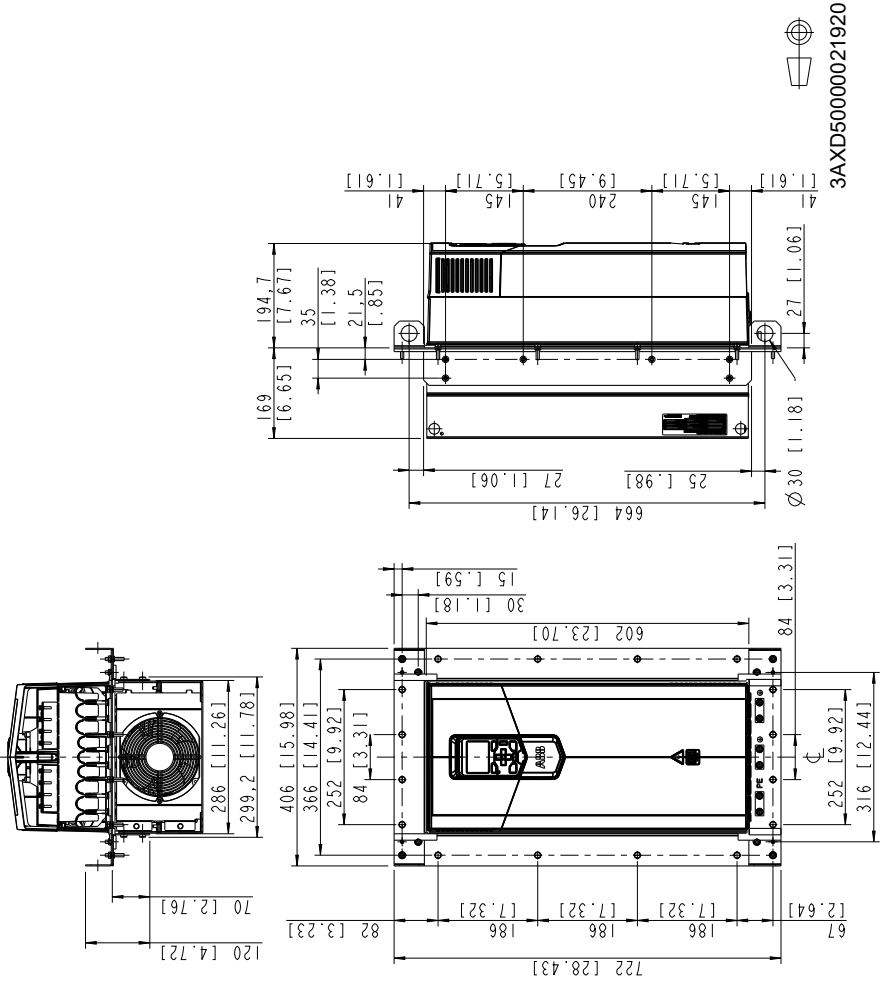

Hood is needed for UL Type 12 installation only

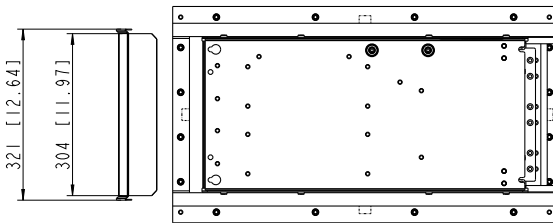
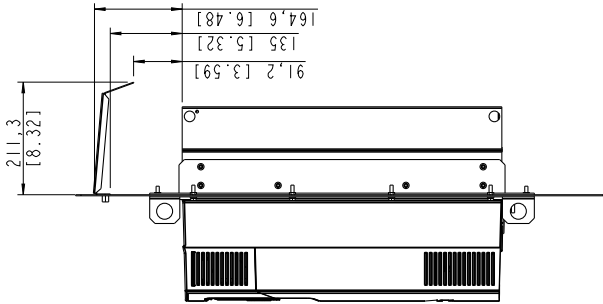
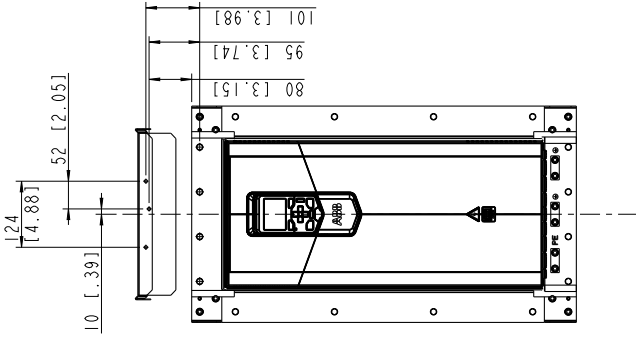

3AXD50000021920

Hood is needed for UL Type 12 installation only

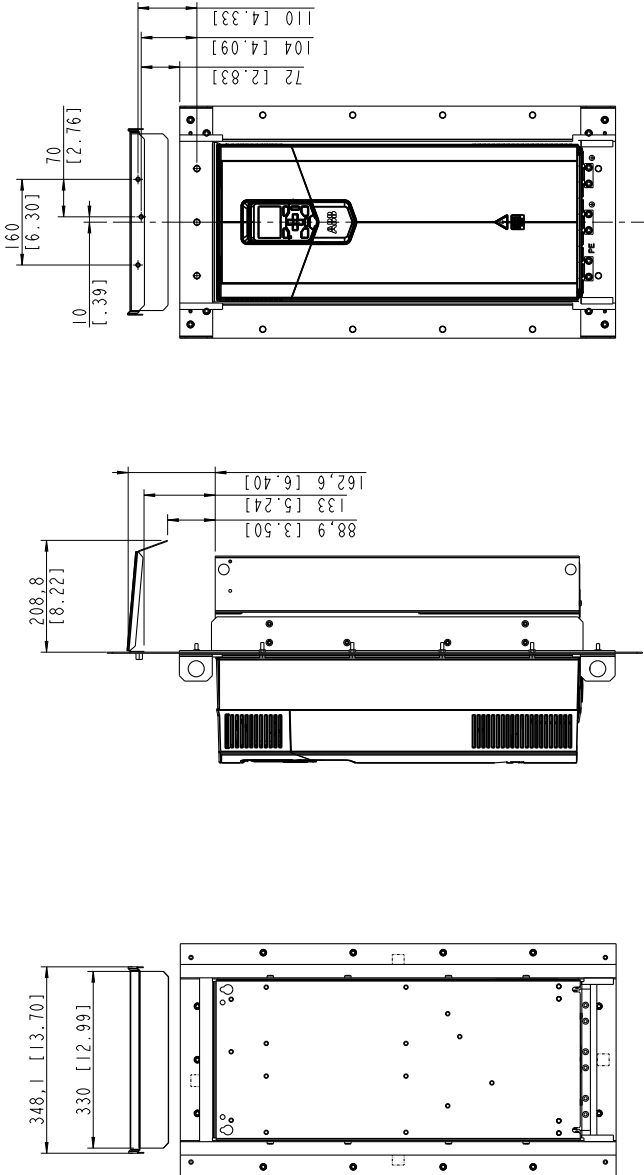

3AXD50000021921

■ Attaching points and opening dimensions

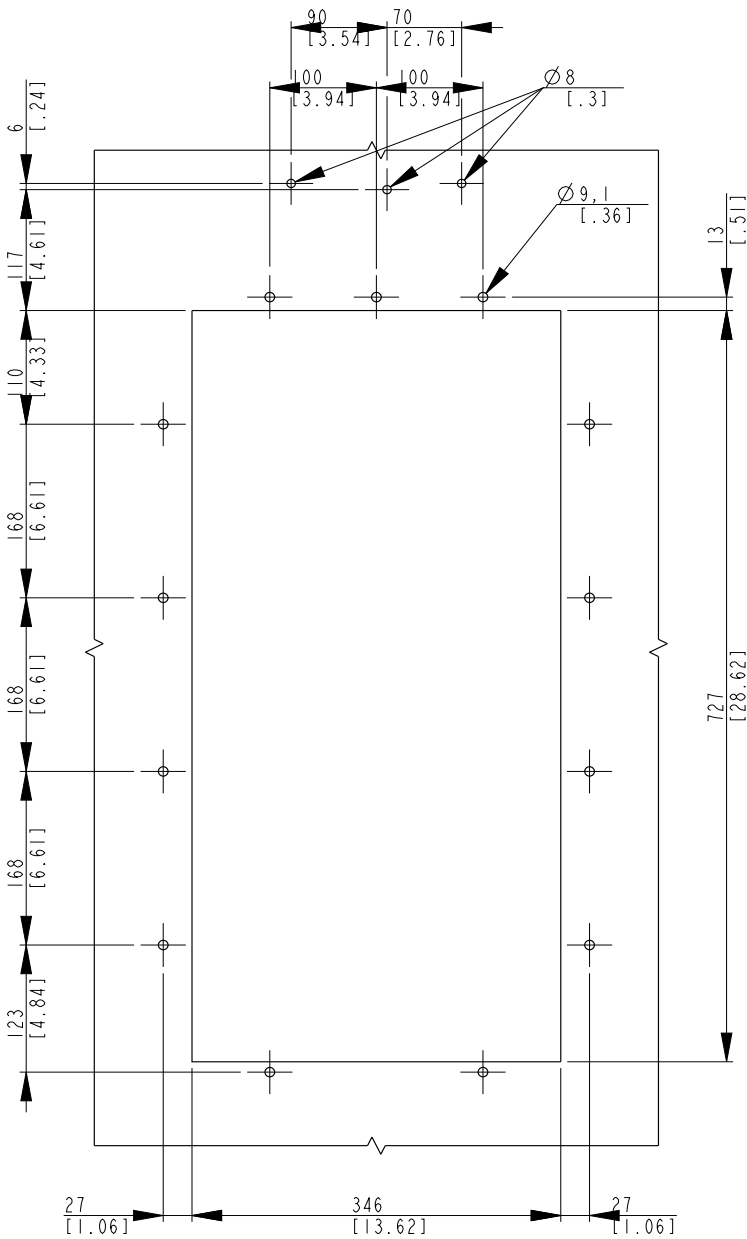

Hood is needed for UL Type 12 installation only

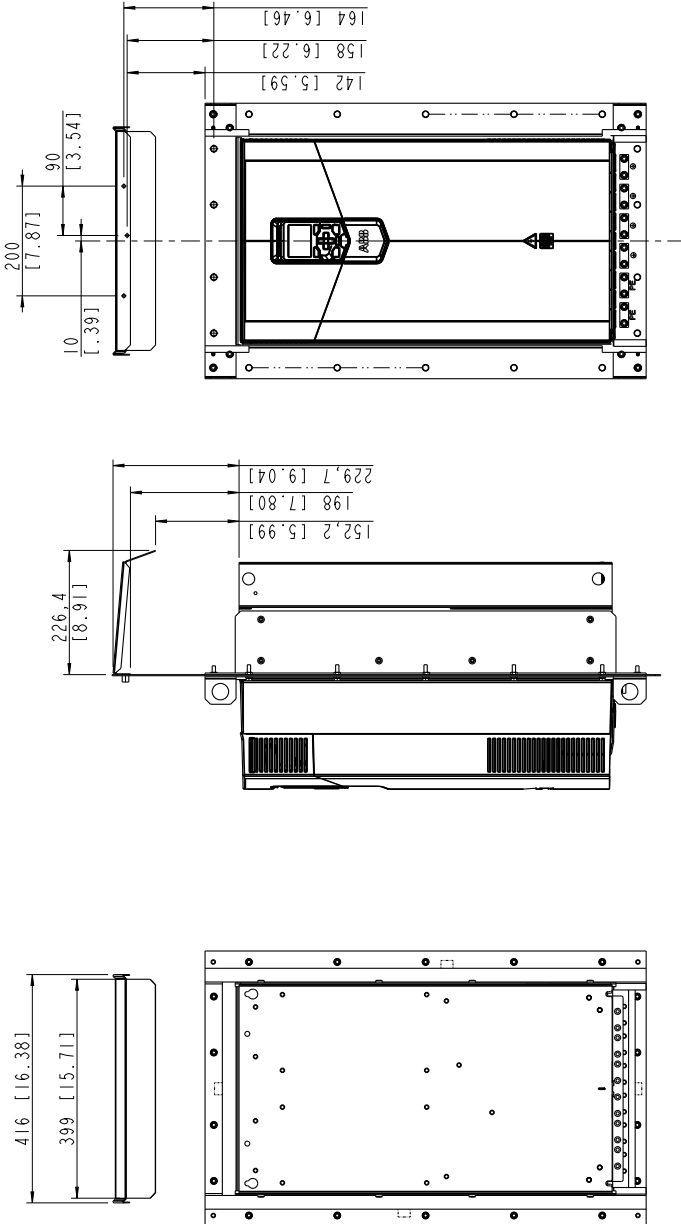

3AXD50000021922

■ Attaching points and opening dimensions

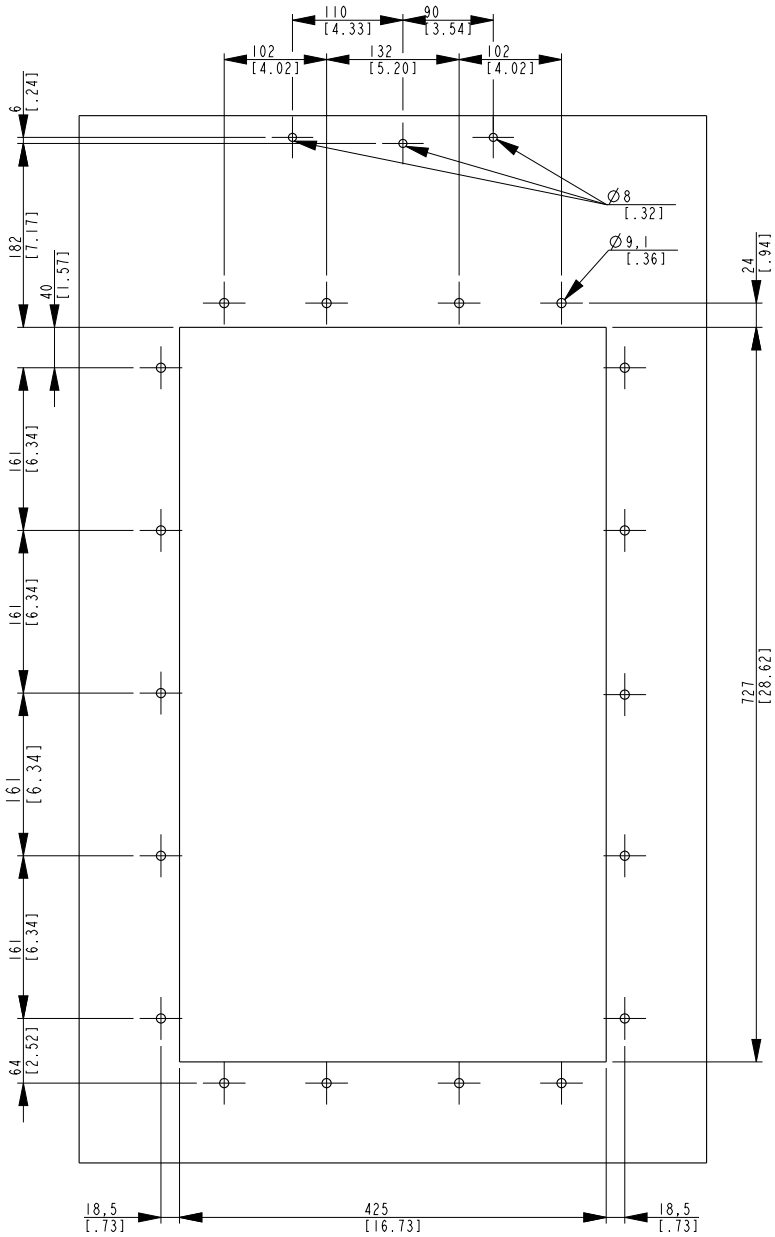



Mounting examples

Contents of this chapter

This chapter contains flange mounting examples in a cooling channel.

Frame R1

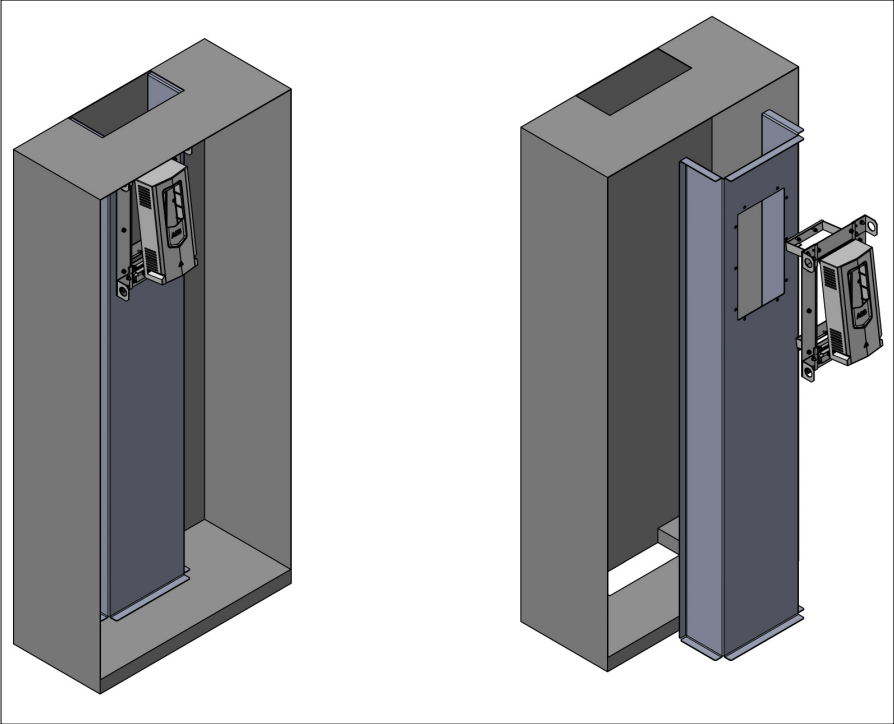

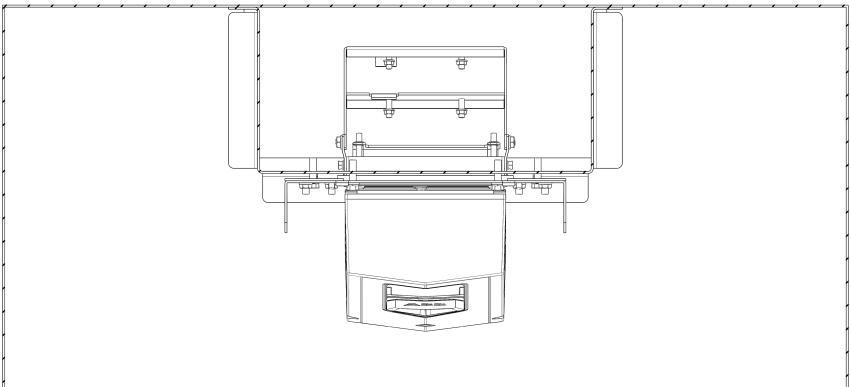
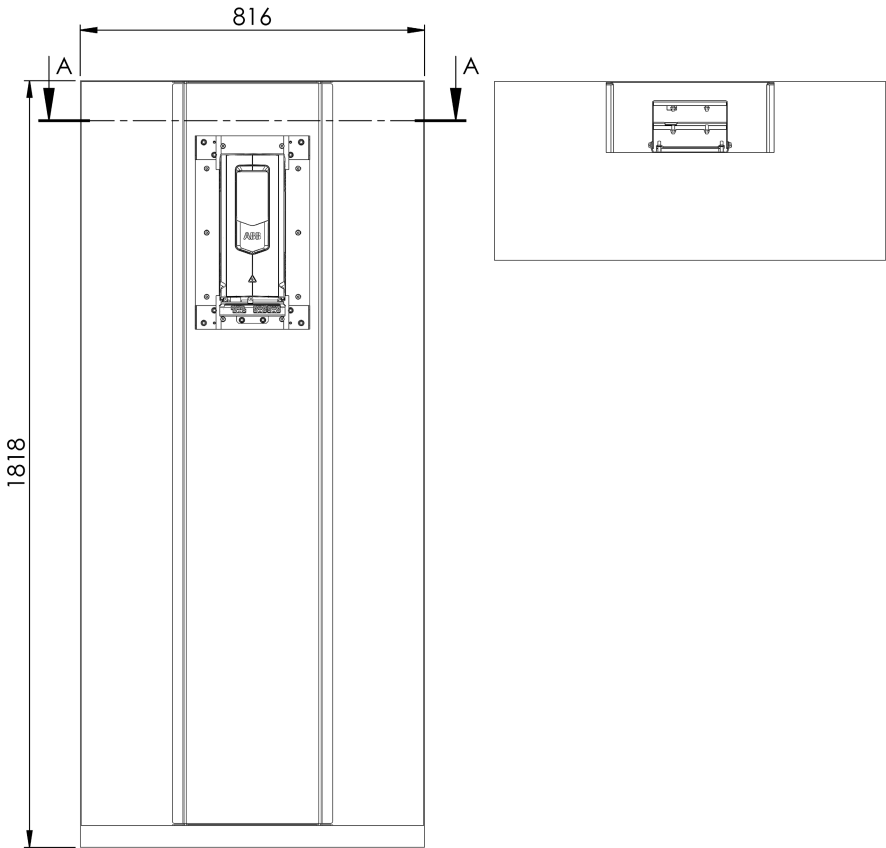

A-A (1 : 5)

74 Mounting examples

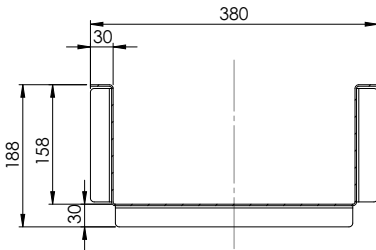
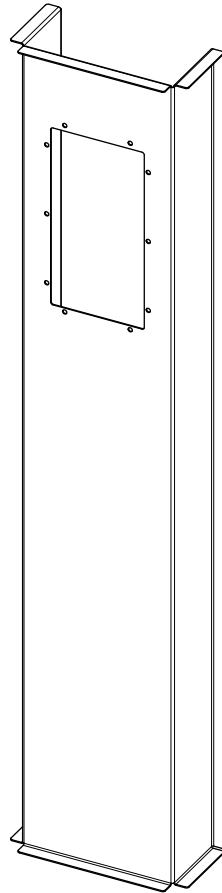
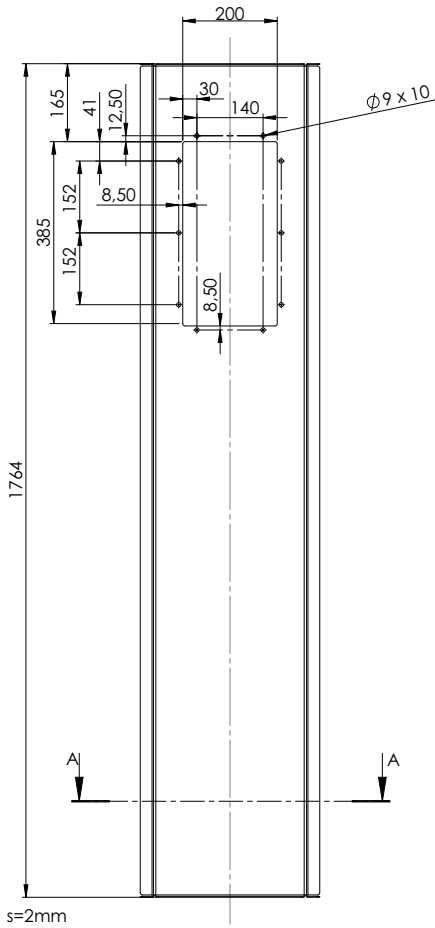

SECTION-A-A SCALE 1 : 5

Frame R2

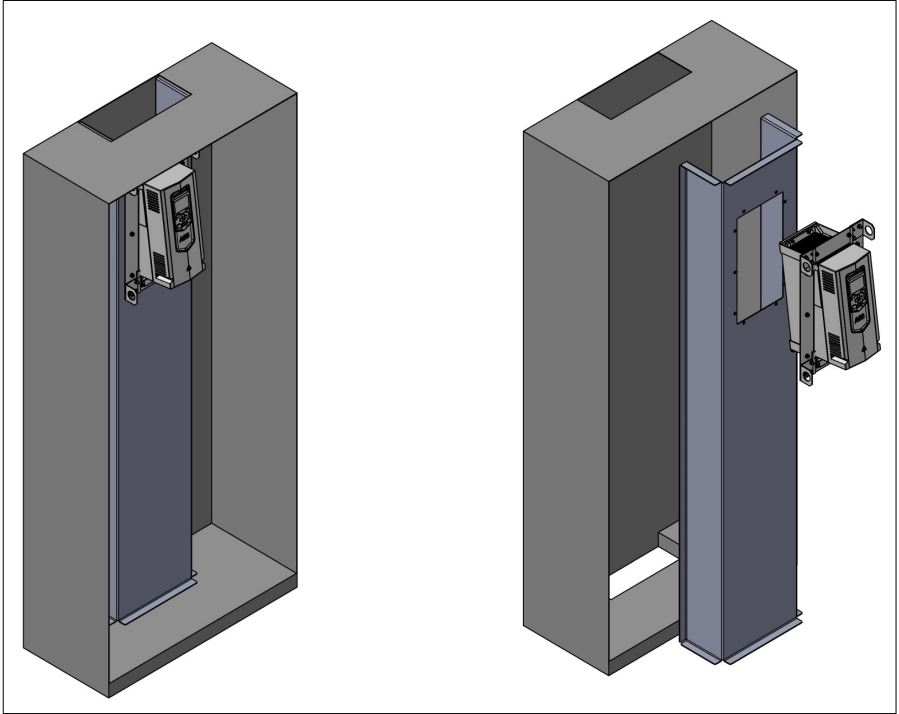

76 Mounting examples

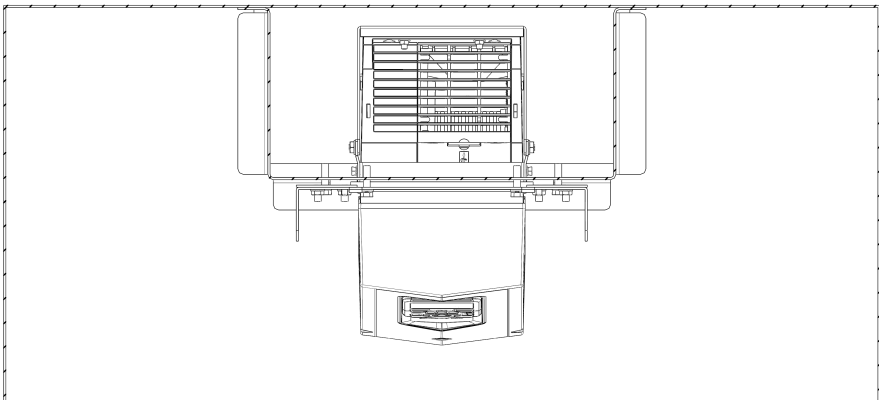
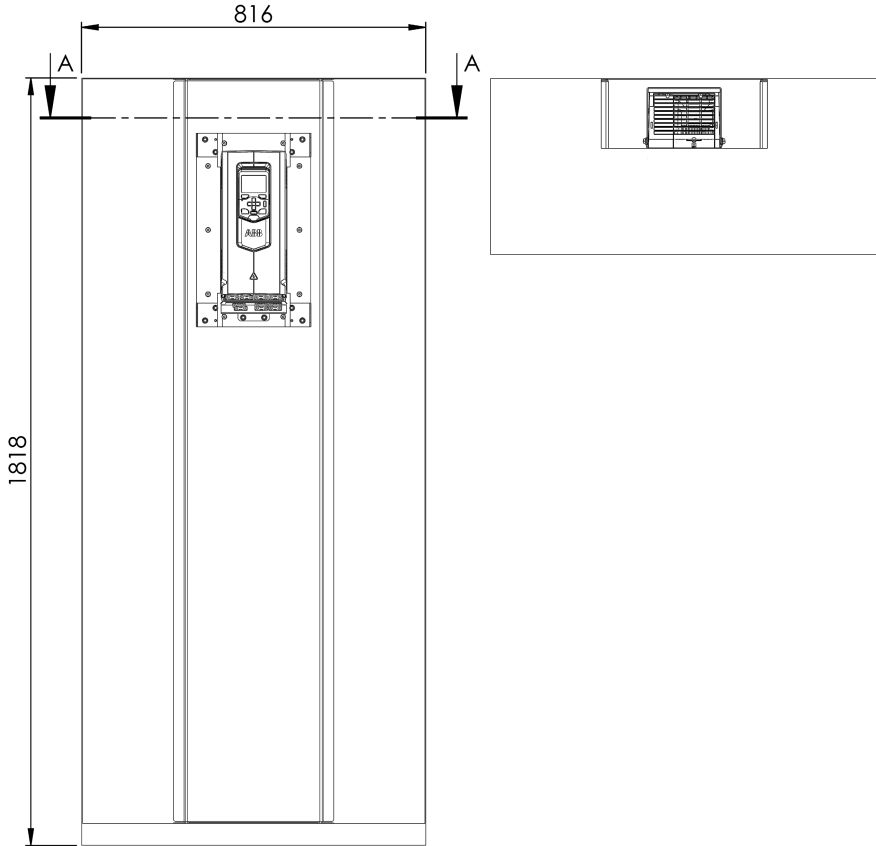

A-A (1 : 5)

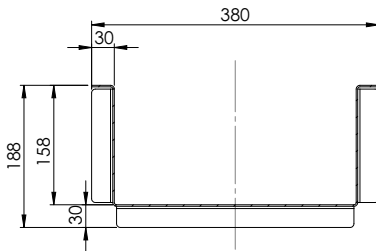
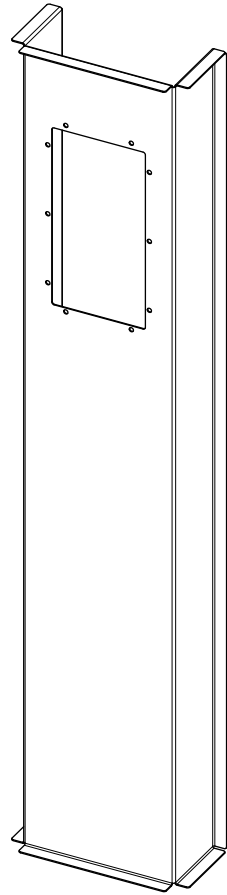
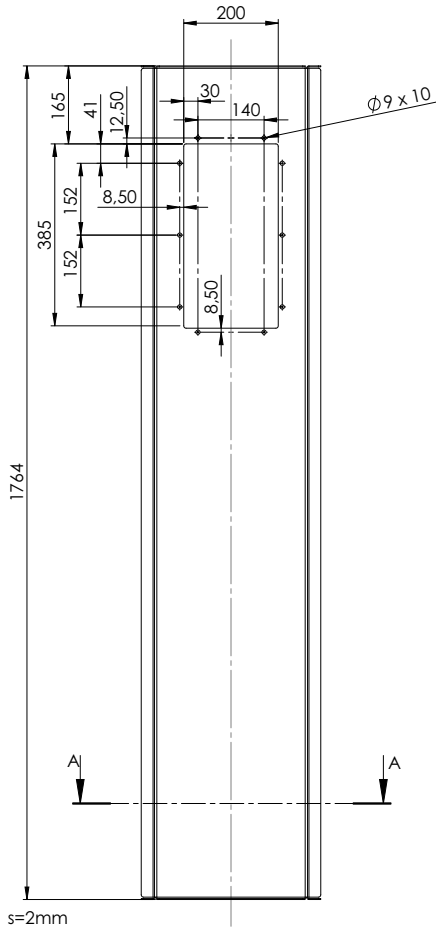

SECTION A-A SCALE 1 : 5

Frame R3

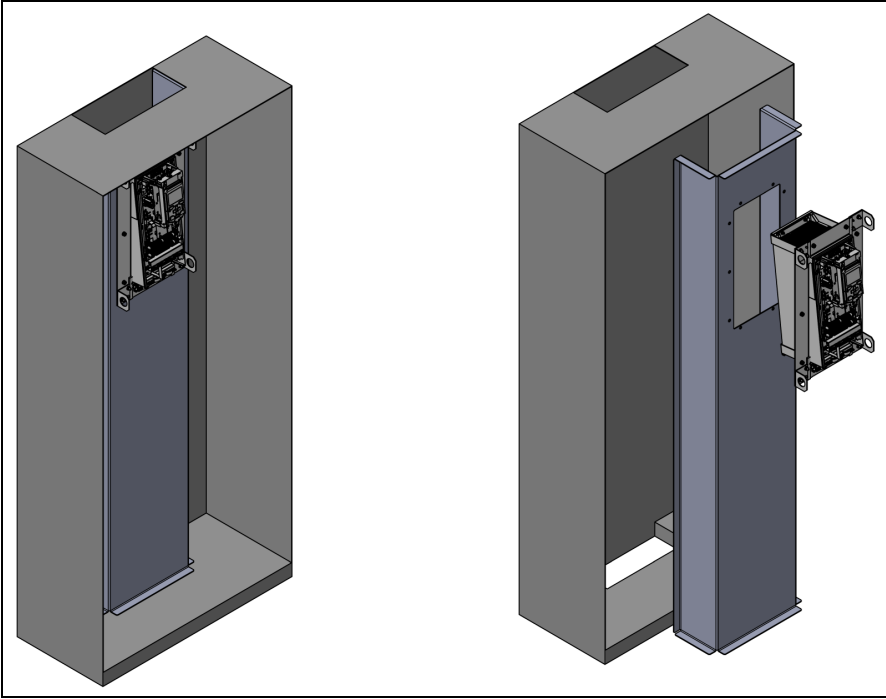

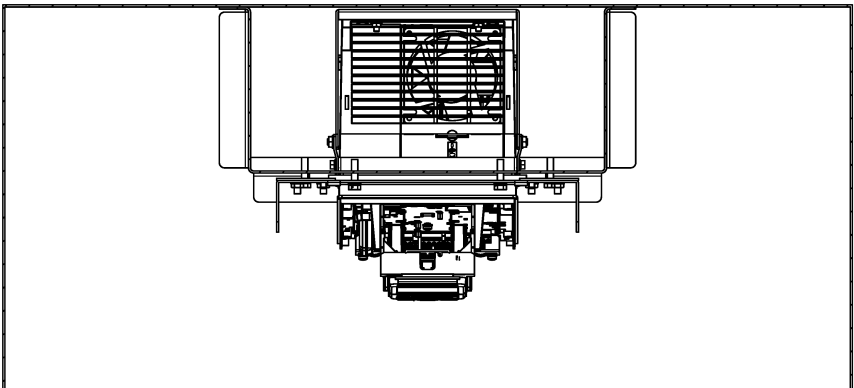
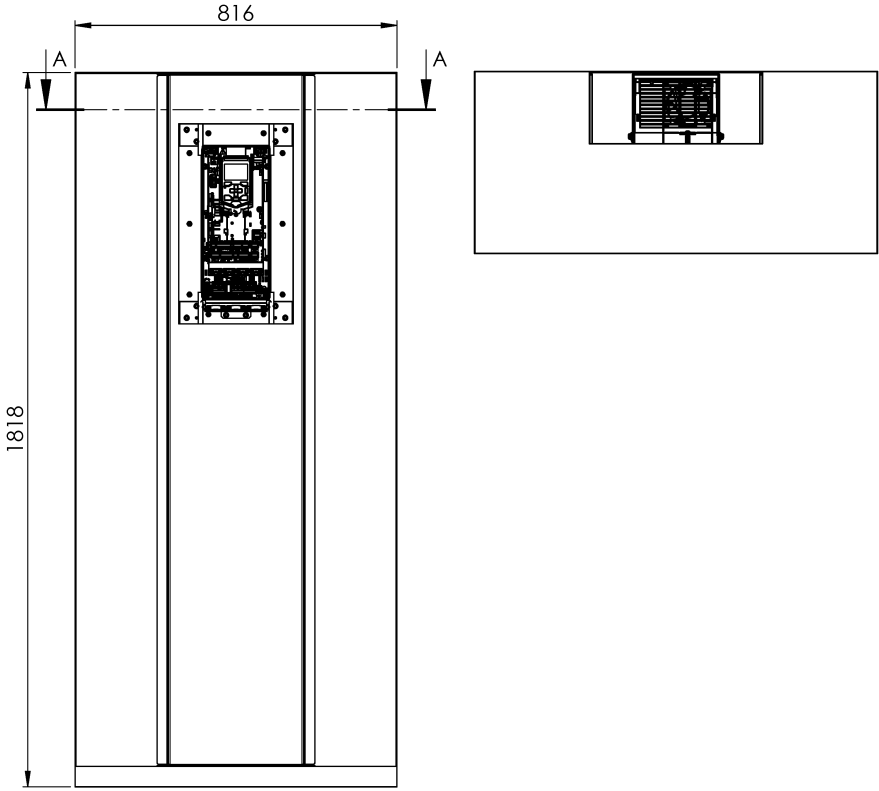

A-A (1 : 5)

80 Mounting examples

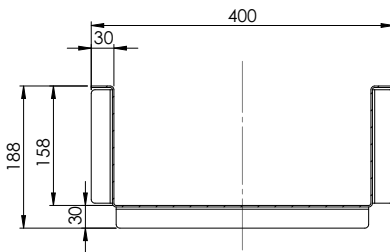
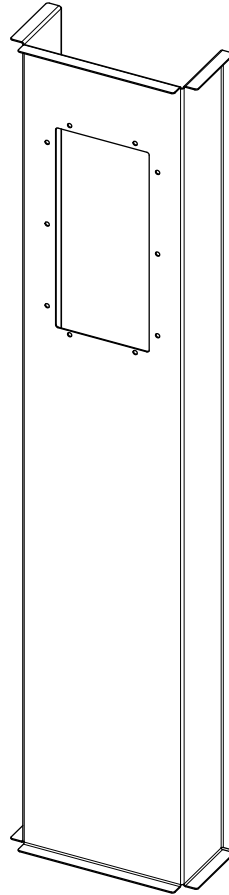
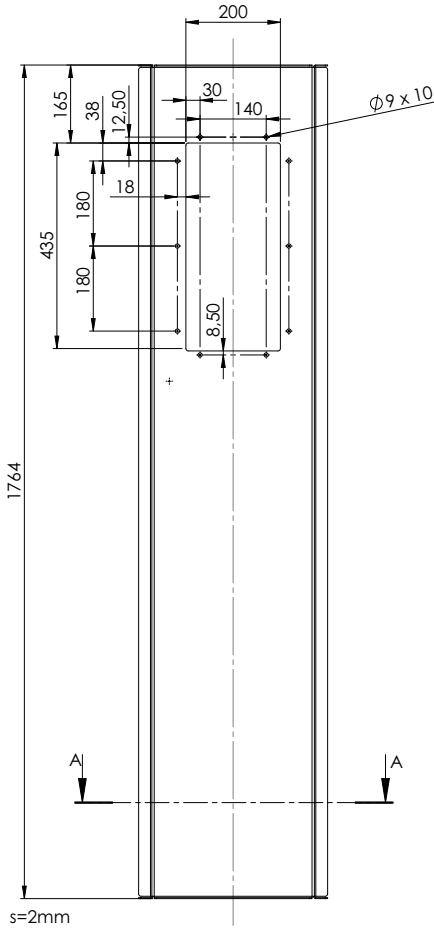

SECTION A-A SCALE 1 : 5

Frame R4

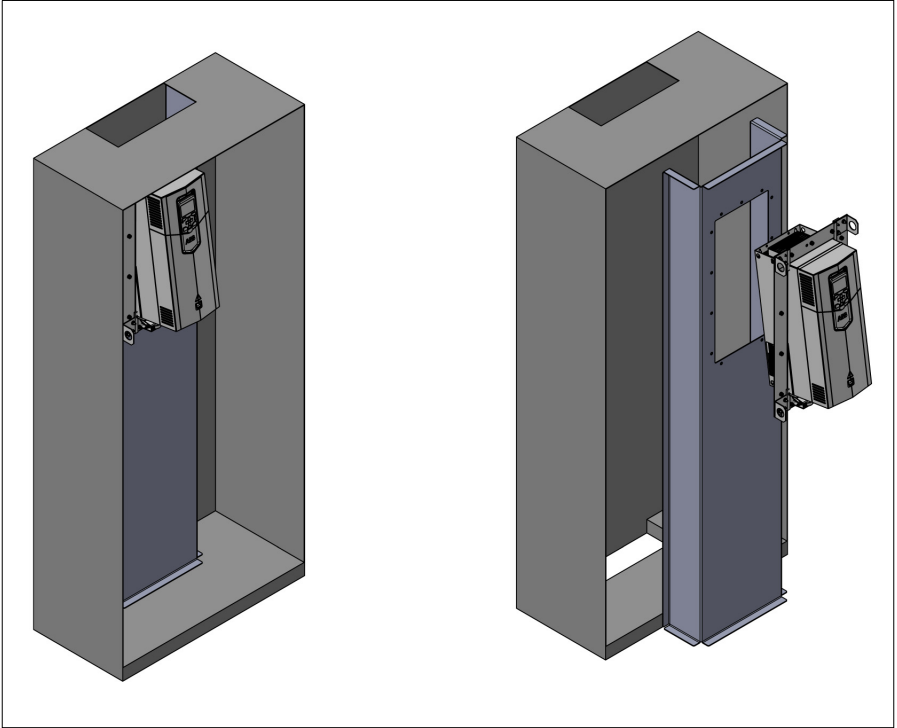

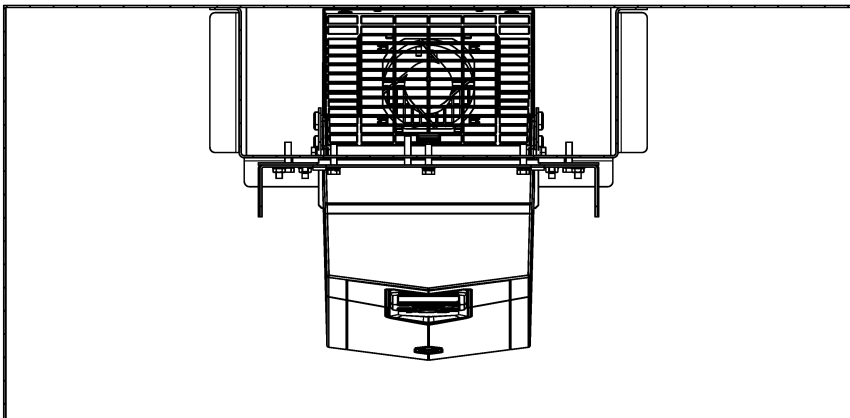
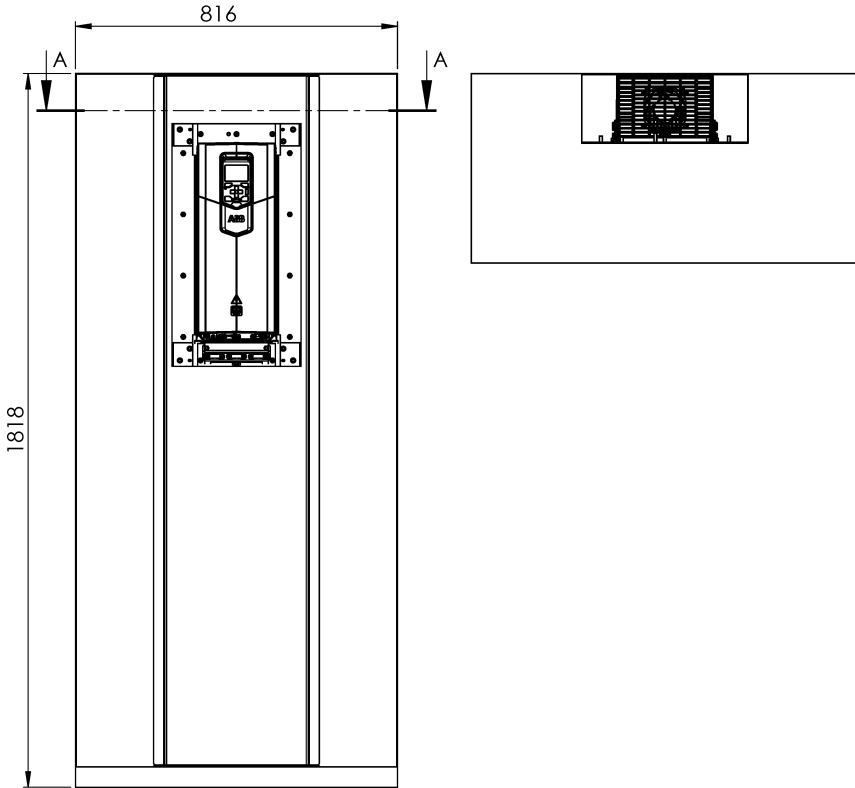

A-A (1 : 5)

Frame R5

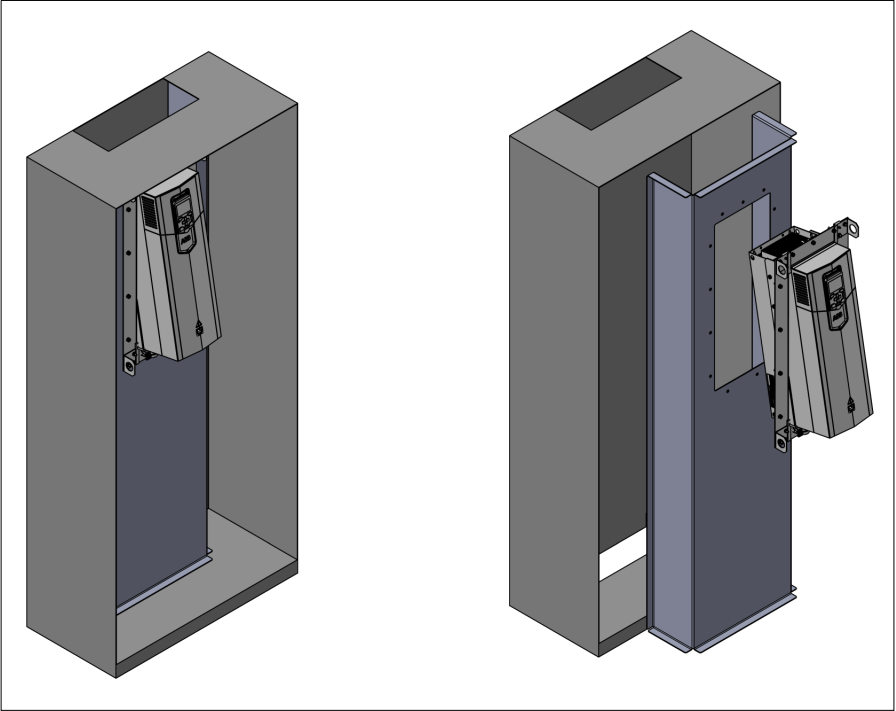

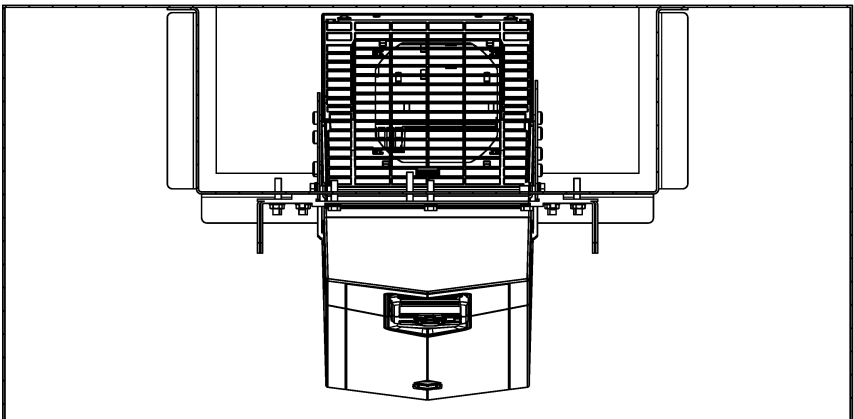
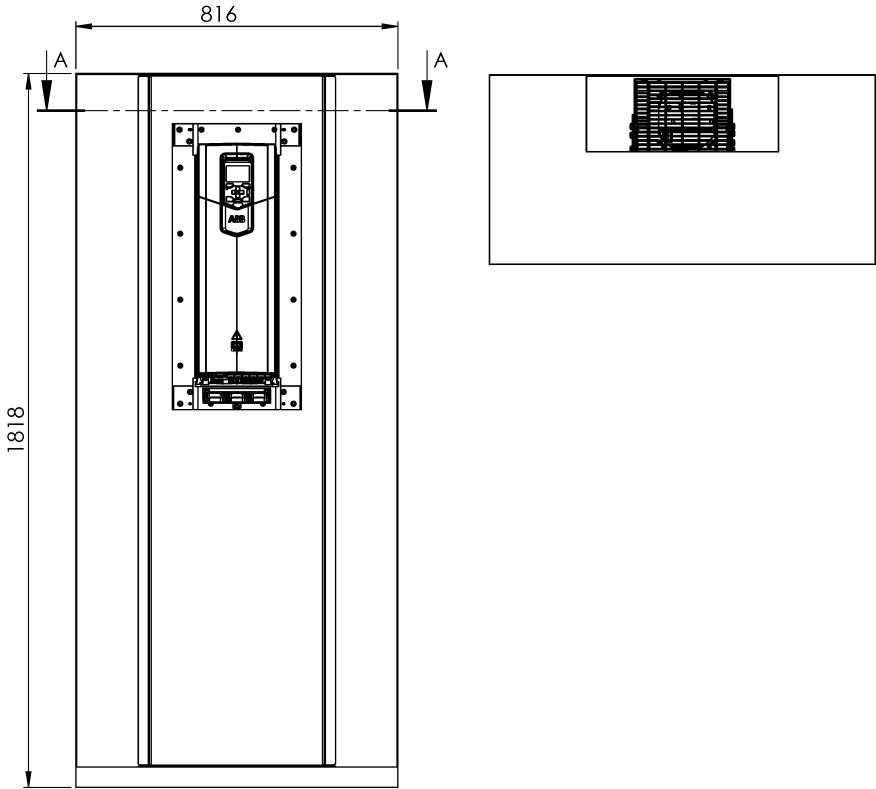

A-A (1 : 5)

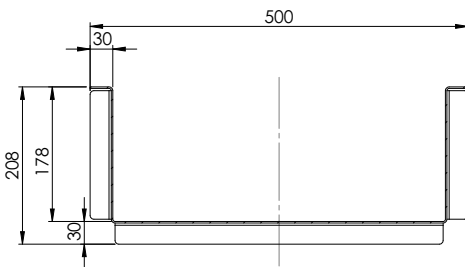
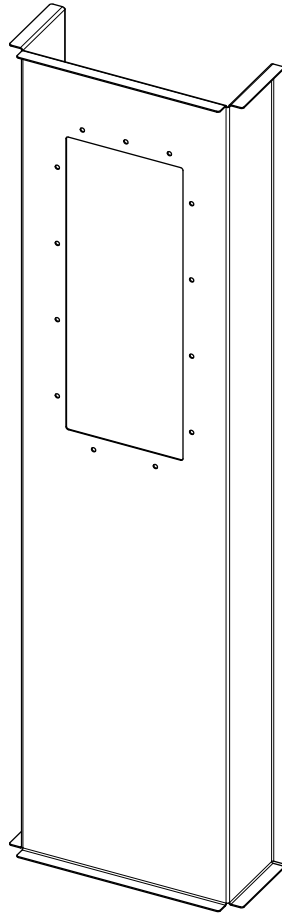
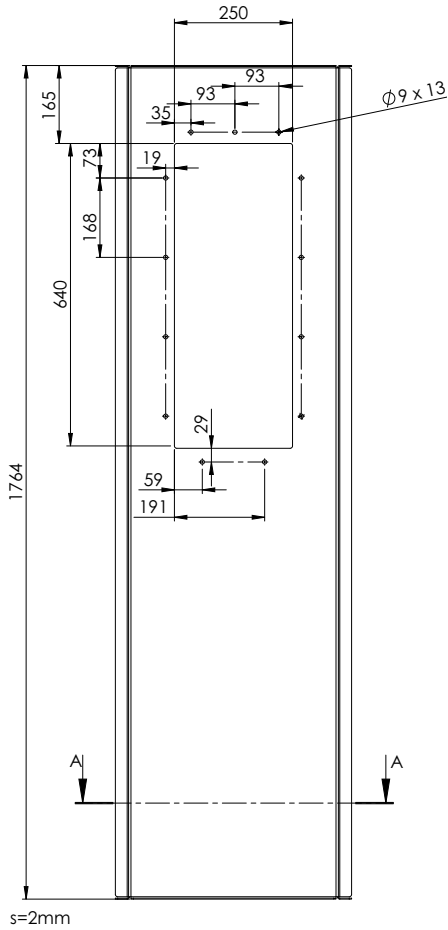

SECTION A-A SCALE 1 : 5

Frame R6

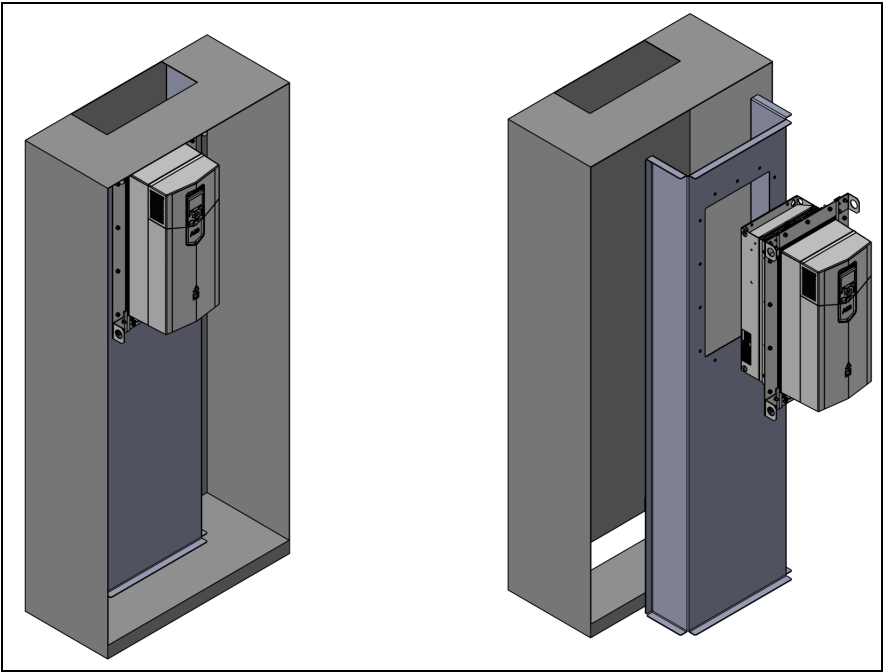

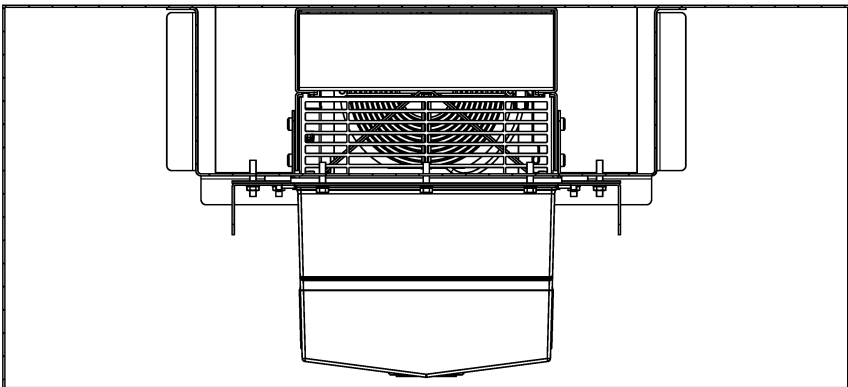
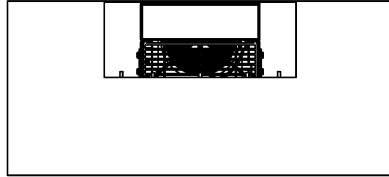
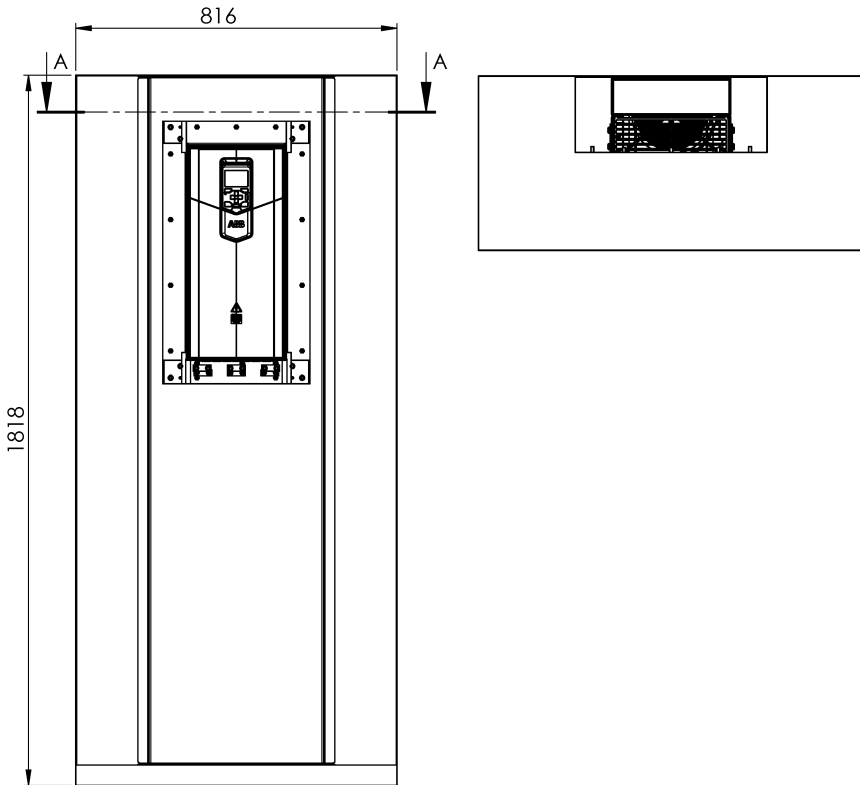

A-A (1 : 5)

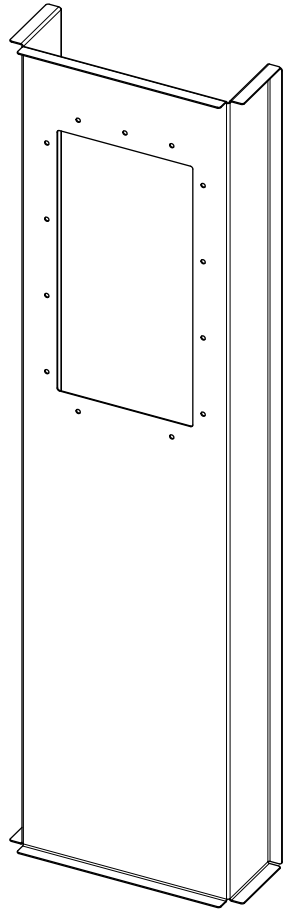
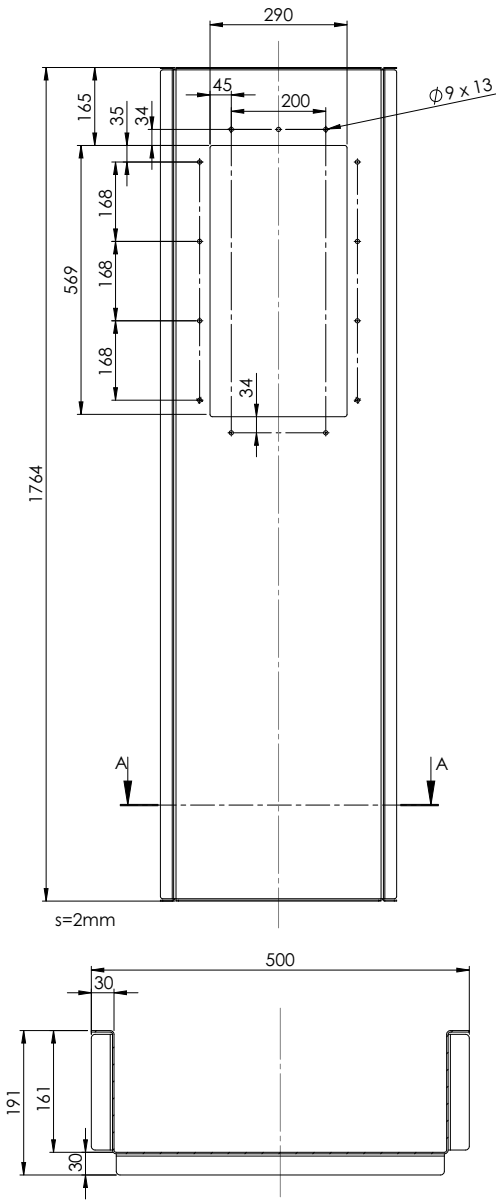

SECTION-A-A SCALE 1 : 5

Frame R7

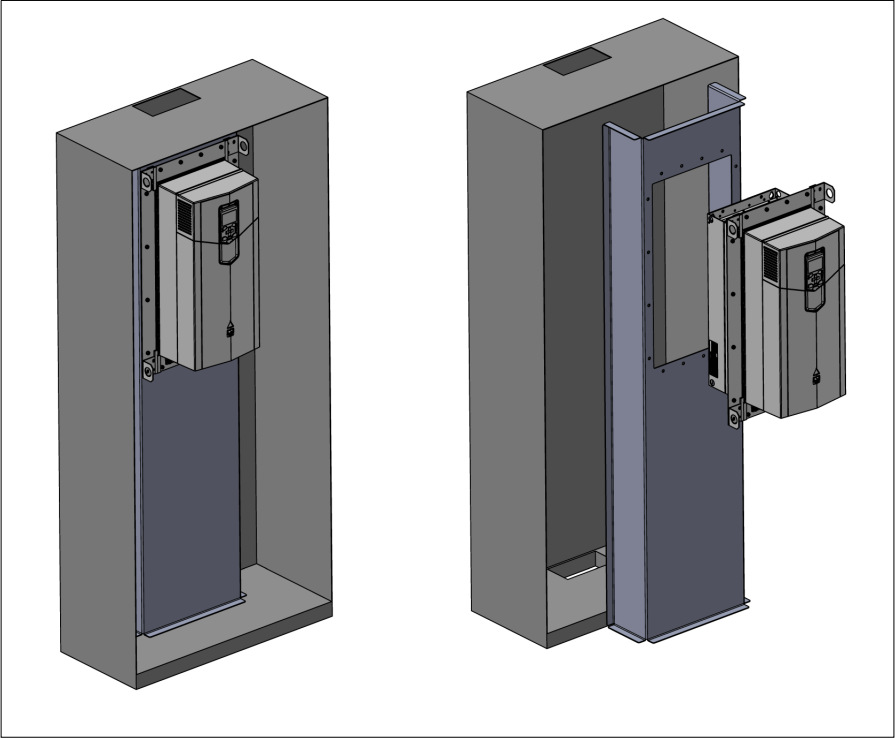

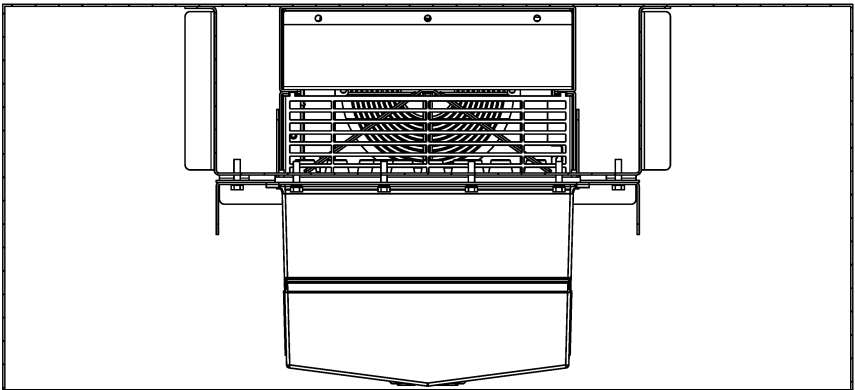
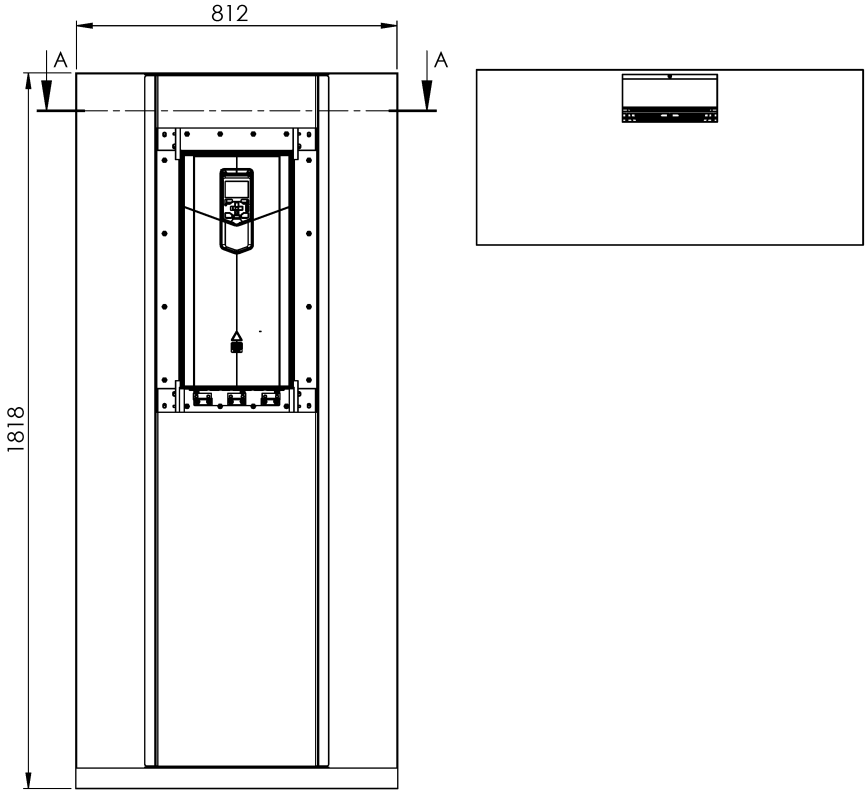

A-A (1 : 5)

Frame R8

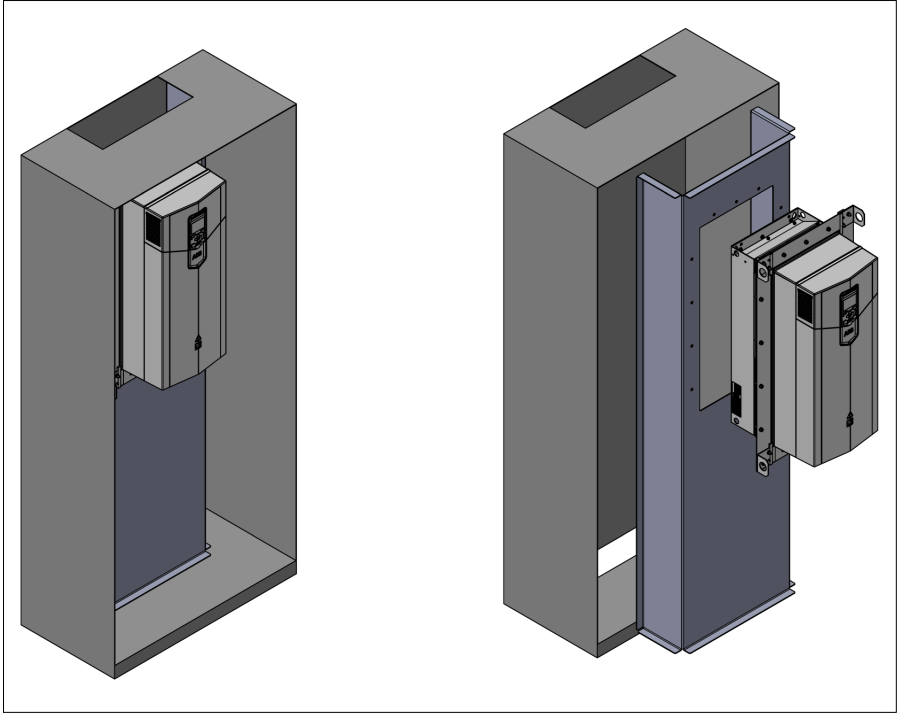

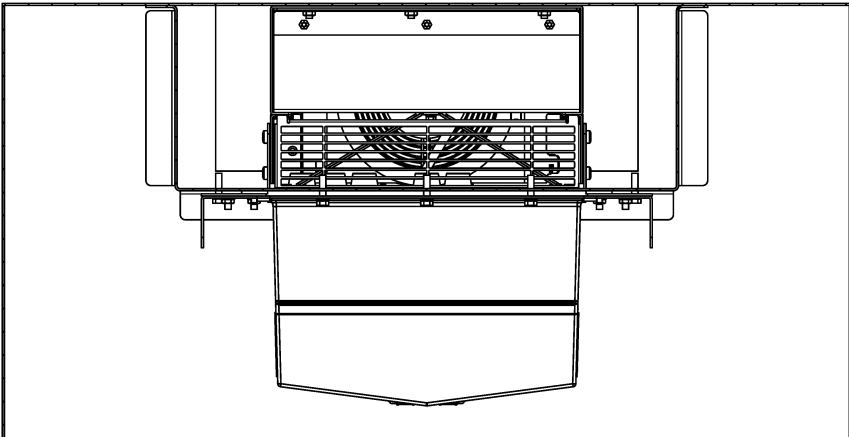
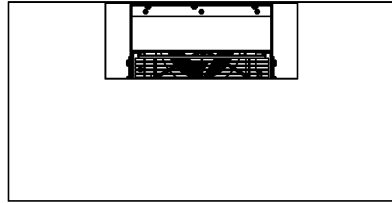
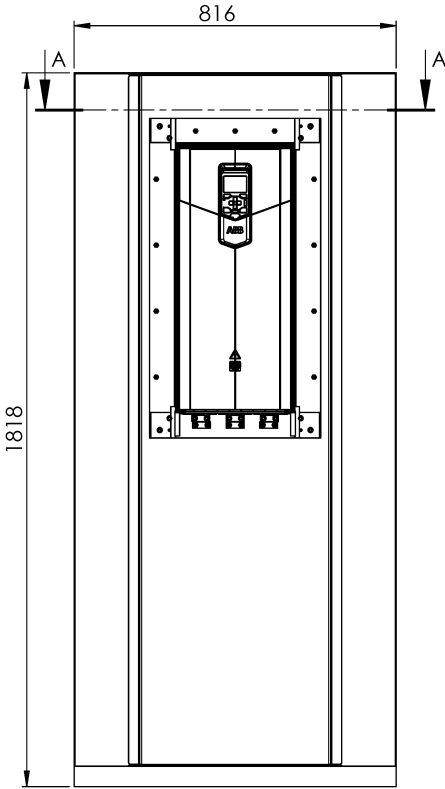

A-A (1 : 5)

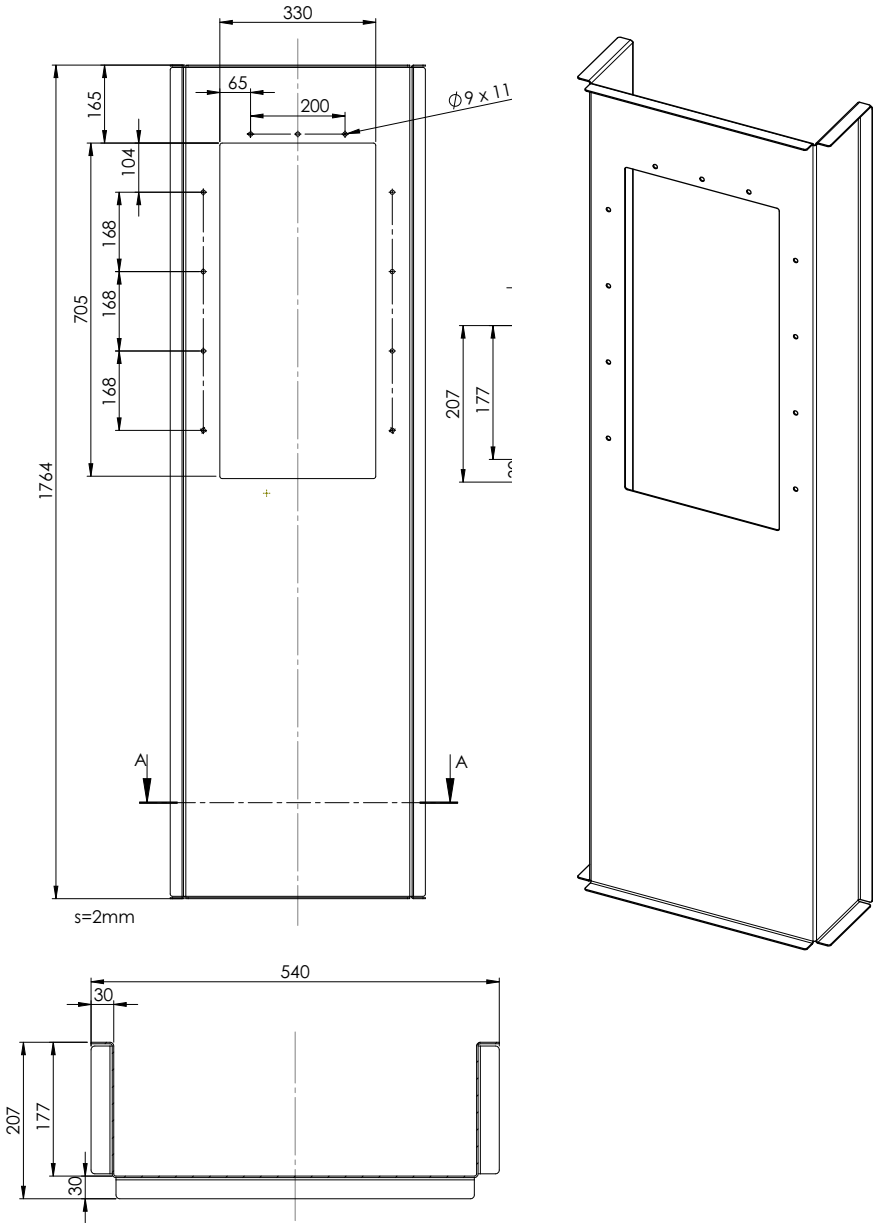

SECTION A-A SCALE 1 : 5

Frame R9

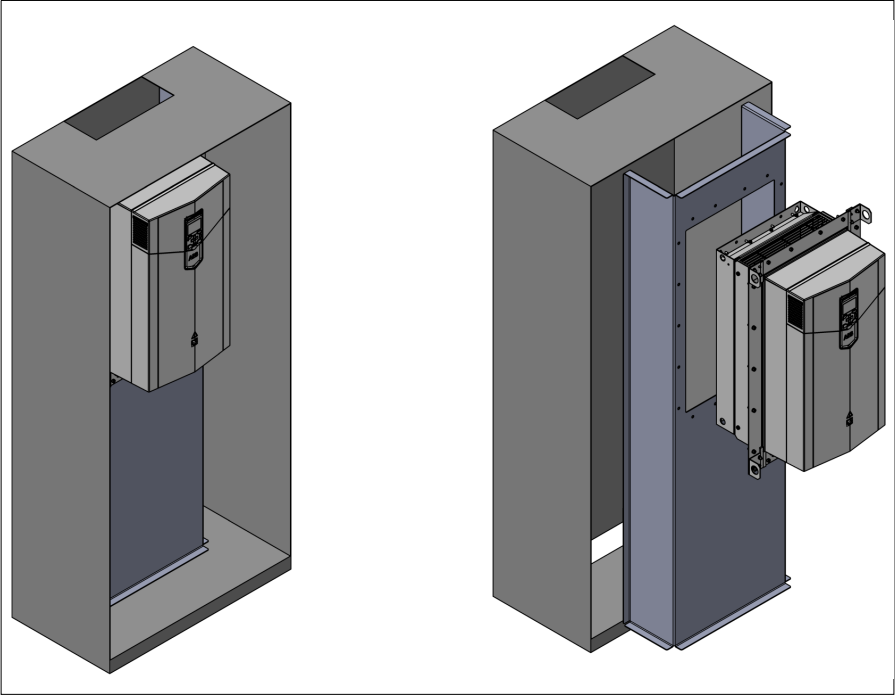

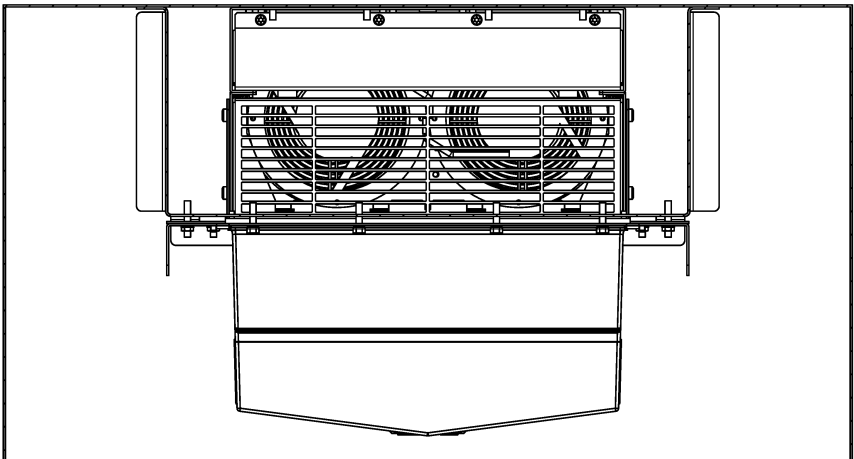
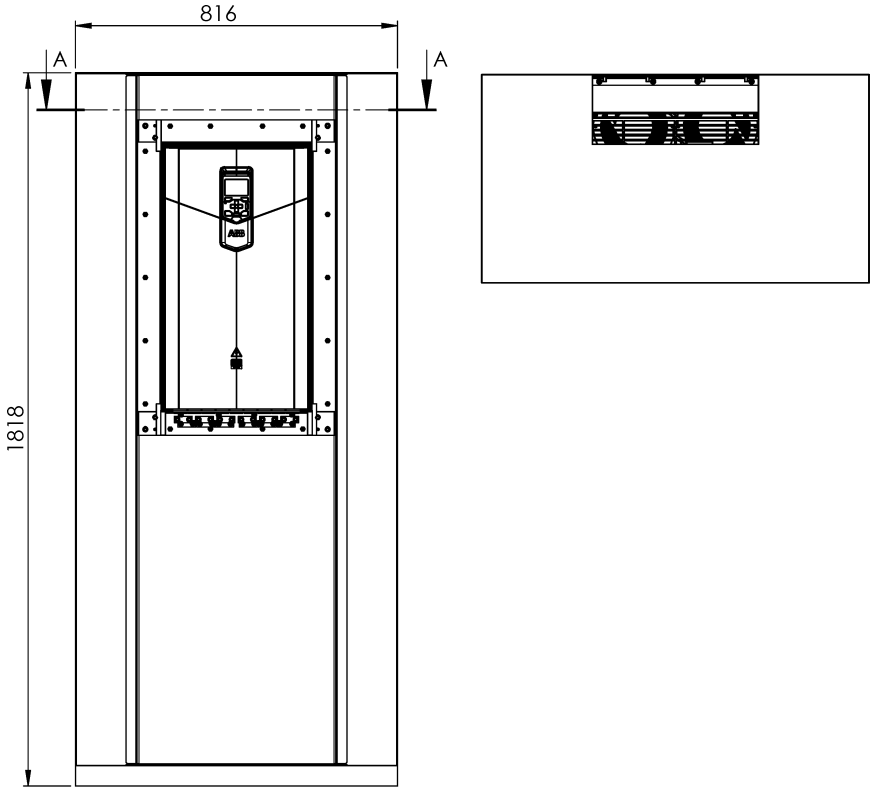

A-A (1 : 5)

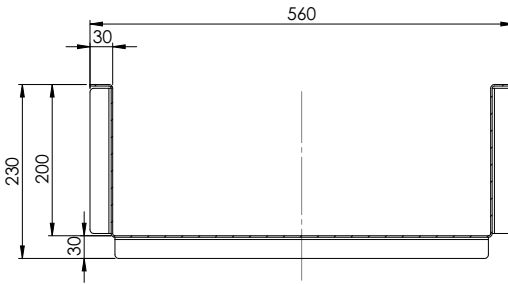
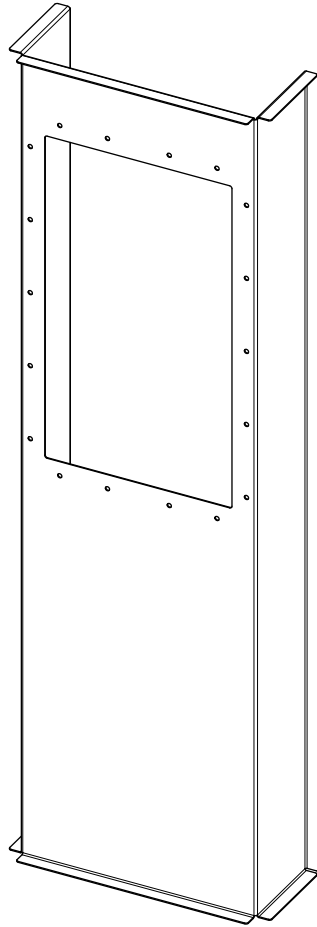
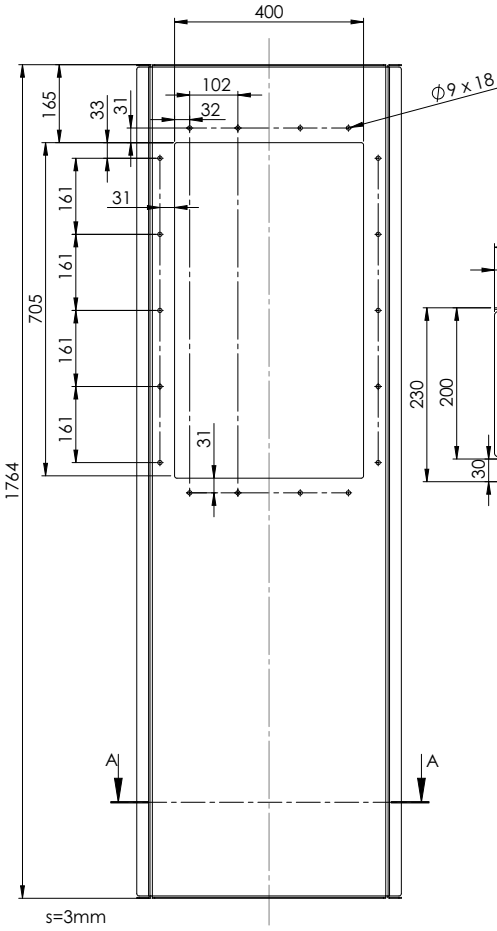

SECTION-A-A SCALE 1 : 5

Further information

Product and service inquiries

Address any inquiries about the product to your local ABB representative, quoting the type designation and serial number of the unit in question. A listing of ABB sales, support and service contacts can be found by navigating to abb.com/searchchannels.

Product training

For information on ABB product training, navigate to new.abb.com/service/training.

Providing feedback on ABB Drives manuals

Your comments on our manuals are welcome. Navigate to new.abb.com/drives/manuals-feedback-form.

Document library on the Internet

You can find manuals and other product documents in PDF format on the Internet at abb.com/drives/documents.



abb.com/drives

