

Rosemount™ 2051 Pressure Transmitter and Rosemount 2051CF Series Flow Meter

with 4–20 mA HART® and 1–5 Vdc Low
Power HART Protocol (Revision 5 and 7)



Safety messages

This guide provides basic guidelines for the Rosemount 2051HT Transmitter. It does not provide instructions for configuration, diagnostics, maintenance, service, troubleshooting, Explosion-proof, Flameproof, or intrinsically safe (I.S.) installations.

⚠ CAUTION

The products described in this document are NOT designed for nuclear-qualified applications. Using non-nuclear qualified products in applications that require nuclear-qualified hardware or products may cause inaccurate readings. For information on Rosemount nuclear-qualified products, contact your local Emerson Sales Representative.

⚠ WARNING

Explosions could result in death or serious injury.

Installation of this transmitter in an explosive environment must be in accordance with the appropriate local, national, and international standards, codes, and practices. Review the approvals section of this manual for any restrictions associated with a safe

- Before connecting a Field Communicator in an explosive atmosphere, ensure the instruments in the loop are installed in accordance with intrinsically safe or non-incendive field wiring practices.
- In an explosion-proof/flameproof installation, do not remove the transmitter covers when power is applied to the unit.

Process leaks may cause harm or result in death.

- Install and tighten process connectors before applying pressure.
- Do not attempt to loosen or remove flange bolts while the transmitter is in service.

Electrical shock can result in death or serious injury.

- Avoid contact with the leads and terminals. High voltage that may be present on leads can cause electrical shock.
- Before connecting a handheld communicator in an explosive atmosphere, ensure the instruments in the loop are installed in accordance with intrinsically safe or non-incendive field wiring practices.
- In an Explosion-Proof/Flameproof installation, do not remove the transmitter covers when power is applied to the unit.

Process leaks may cause harm or result in death.

- Install and tighten process connectors before applying pressure.

Physical access

- Unauthorized personnel may potentially cause significant damage to and/or misconfiguration of end users' equipment. This could be intentional or unintentional and needs to be protected against.
- Physical security is an important part of any security program and fundamental to protecting your system. Restrict physical access by unauthorized personnel to protect end users' assets. This is true for all systems used within the facility.

⚠ WARNING

Replacement equipment or spare parts not approved by Emerson for use as spare parts could reduce the pressure retaining capabilities of the transmitter and may render the instrument dangerous.

- Use only bolts supplied or sold by Emerson as spare parts.

Improper assembly of manifolds to traditional flange can damage sensor module.

For safe assembly of manifold to traditional flange, bolts must break back plane of flange web (i.e., bolt hole) but must not contact sensor module housing.

Contents

System readiness..... 5

Mount the transmitter.....6

Housing rotation..... 13

Set the switches..... 14

Connect the wiring and power up..... 15

Verify configuration..... 18

Trim the transmitter.....22

Safety instrumented systems..... 25

Product certifications..... 26

1 System readiness

1.1 Confirm HART Revision capability

- If using HART based control or asset management systems, confirm the HART capability of those systems prior to transmitter installation. Not all systems are capable of communicating with HART Revision 7 protocol. This transmitter can be configured for either HART Revision 5 or 7.
- For instructions on how to change the HART Revision of your transmitter, see [Switch HART Revision mode](#).

1.2 Confirm correct device driver

- Verify the correct device driver (DD/DTM™) is loaded on your systems to ensure proper communications.
- Download the correct device driver at your host vendor download site, [Emerson.com](#) or [Fieldbus.org](#).

2 Mount the transmitter

2.1 Liquid applications

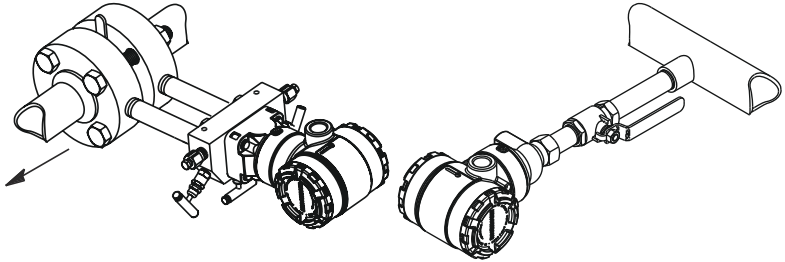

Procedure

1. Place taps to the side of the line.
2. Mount beside or below the taps.
3. Mount the transmitter so the drain/vent valves are oriented upward.

2.2 Gas applications

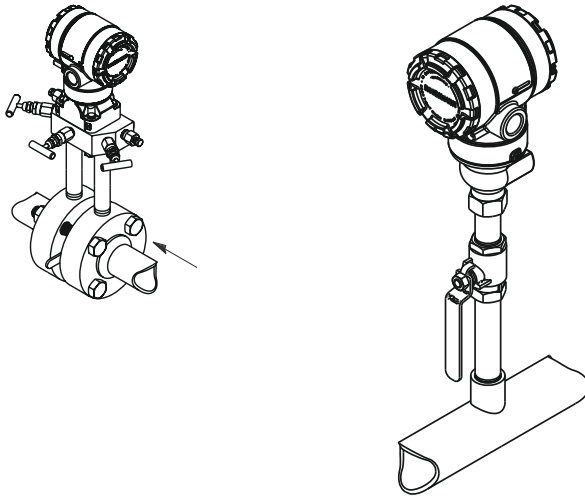

Procedure

1. Place taps in the top or side of the line.
2. Mount beside or above the taps.

2.3 Steam applications

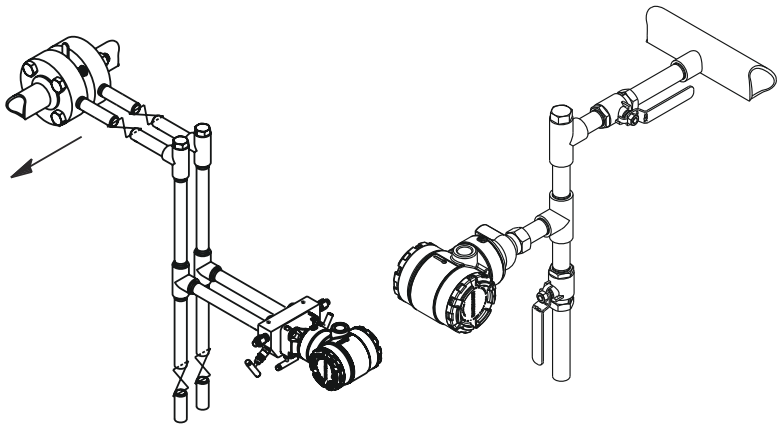

Procedure

1. Place taps to the side of the line.
2. Mount beside or below the taps.
3. Fill impulse lines with water.

Figure 2-1: Panel and Pipe Mounting

Panel mount⁽¹⁾

Pipe mount

Coplanar flange

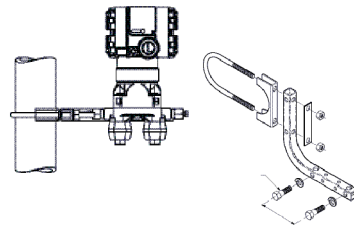
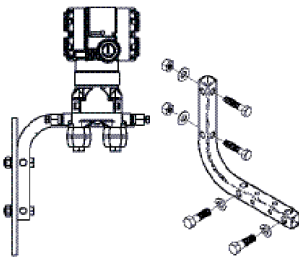

Traditional flange

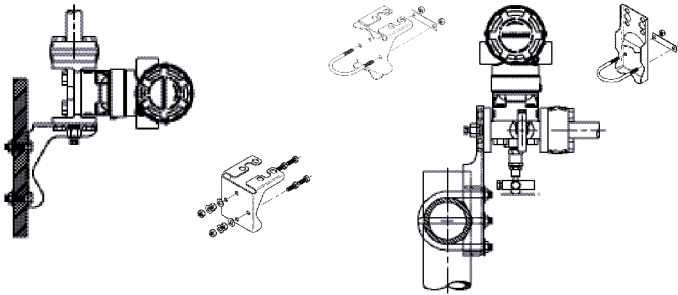

Rosemount 2051T

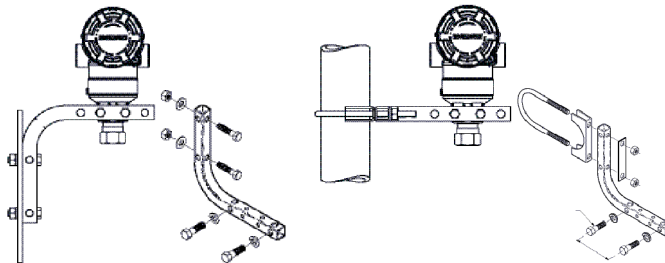

(1) × 1 panel bolts are customer supplied.

2.4 Bolting considerations

If the transmitter installation requires assembly of the process flanges, manifolds, or flange adapters, follow the assembly guidelines to ensure a tight seal for optimal performance characteristics of the transmitters. Use only bolts supplied with the transmitter or sold by Emerson as spare parts. [Figure 2-2](#) illustrates common transmitter assemblies with the bolt length required for proper transmitter assembly.

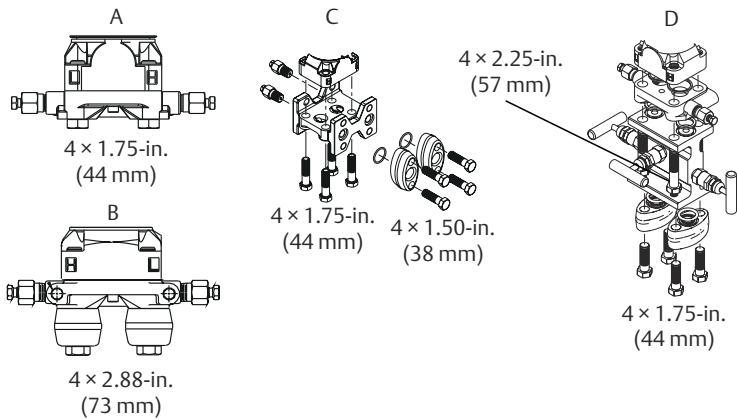
Figure 2-2: Common Transmitter Assemblies

- A. Transmitter with coplanar flange
- B. Transmitter with coplanar flange and optional flange adapters
- C. Transmitter with traditional flange and optional flange adapters
- D. Transmitter with coplanar flange and optional manifold and flange adapters

Bolts are typically carbon steel (CS) or stainless steel (SST). Confirm the material by viewing the markings on the head of the bolt and referencing [Table 2-1](#). If bolt material is not shown in [Table 2-1](#), contact a local Emerson representative for more information.

Carbon steel bolts do not require lubrication and the stainless steel bolts are coated with a lubricant to ease installation. However, no additional lubricant should be applied when installing either type of bolt.

Use the following bolt installation procedure:

Procedure

1. Tighten the bolts by hand.
2. Torque the bolts to the initial torque value using a crossing pattern. See [Table 2-1](#) for initial torque value.
3. Torque the bolts to the final torque value using the same crossing pattern. See [Table 2-1](#) for final torque value.
4. Verify the flange bolts are protruding through the sensor module bolt holes before applying pressure.

Table 2-1: Torque Values for the Flange and Flange Adapter Bolts

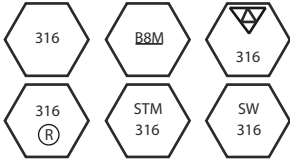
Bolt material	Head markings	Initial torque	Final torque
CS		300 in-lb	650 in-lb
SST		150 in-lb	300 in-lb

2.5 O-rings

The two styles of Rosemount flange adapters (Rosemount 1151 and Rosemount 3051/2051/2024/3095) each require a unique O-ring (see [Figure 2-3](#)). Use only the O-ring designed for the corresponding flange adapter.

⚠ WARNING

Failure to install proper flange adapter O-rings may cause process leaks, which can result in death or serious injury. The two flange adapters are distinguished by unique O-ring grooves. Only use the O-ring that is designed for its specific flange adapter, as shown below. When compressed, PTFE O-rings tend to *cold flow*, which aids in their sealing capabilities.

Figure 2-3: O-rings

ROSEMOUNT 3051S/3051/2051/3001/3095/2024

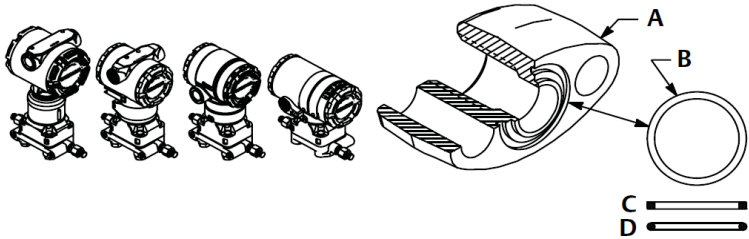

ROSEMOUNT 1151

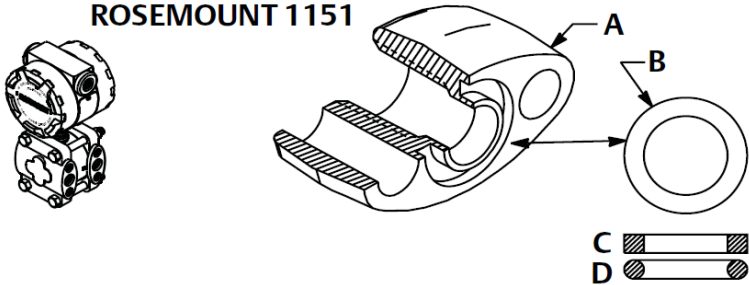

- A. Flange adapter
- B. O-ring
- C. PTFE based
- D. Elastomer

Note

You should replace PTFE O-rings if you remove the flange adapter.

2.6 Environmental seal for housing

Thread sealing (PTFE) tape or paste on male threads of conduit is required to provide a water/dust tight seal and meets requirements of NEMA® Type 4X, IP66, and IP68. Consult factory if other Ingress Protection ratings are required.

For M20 threads, install conduit plugs to full thread engagement or until mechanical resistance is met.

2.7 In-line gage transmitter orientation

The low side pressure port (atmospheric reference) on the in-line gage transmitter is located in the neck of the transmitter, behind the housing. The vent path is 360° around the transmitter between the housing and sensor. (See [Figure 2-4.](#))

Keep the vent path free of any obstruction, including but not limited to paint, dust, and lubrication by mounting the transmitter so fluids can drain away.

Figure 2-4: In-line Gage Low Side Pressure Port

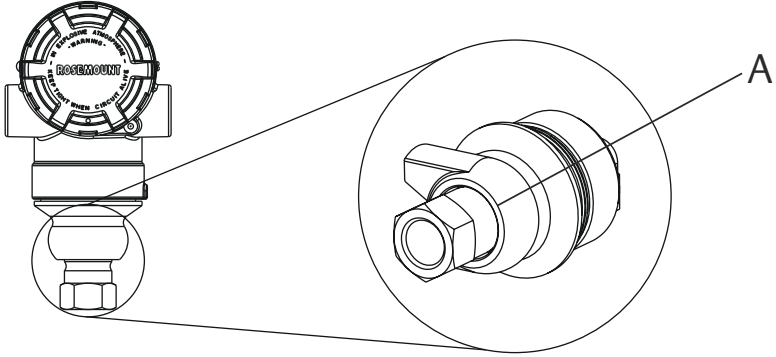

A. Pressure port location

3 Housing rotation

To improve field access to wiring or to better view the optional LCD display follow the Procedure steps.

Figure 3-1: Housing Rotation

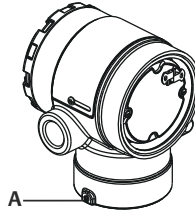

A. *Housing rotation set screw (5/64 in.)*

Procedure

1. Loosen the housing rotation set screw using a 5/64 -in. hex wrench.
2. Rotate the housing clockwise to the desired location.
3. If the desired location cannot be achieved due to thread limit, rotate the housing counterclockwise to the desired location (up to 360° from thread limit).
4. Retighten the housing rotation set screw to no more than 7 in-lbs when desired location is reached.

4 Set the switches

Set alarm and security switch configuration before installation as shown in [Figure 4-1](#).

- The alarm switch sets the analog output alarm to high or low.
- Default alarm is high.
- The security switch allows (🔓) or prevents (🔒) any configuration of the transmitter.
- Default security is off (🔓).

Use the following procedure to change the switch configuration:

Procedure

1. If the transmitter is installed, secure the loop, and remove power.
2. Remove the housing cover opposite the field terminal side. Do not remove the instrument cover in explosive atmospheres when the circuit is live.
3. Slide the security and alarm switches into the preferred position using a small screwdriver.
4. Reattach the transmitter cover. The cover must be fully engaged to comply with explosion-proof requirements.

Example

Figure 4-1: Transmitter Electronics Board

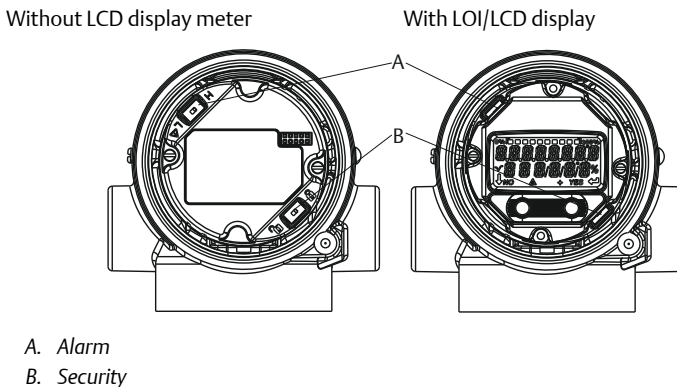

5 Connect the wiring and power up

Figure 5-1: Transmitter Wiring Diagrams (4–20 mA)

Aluminum

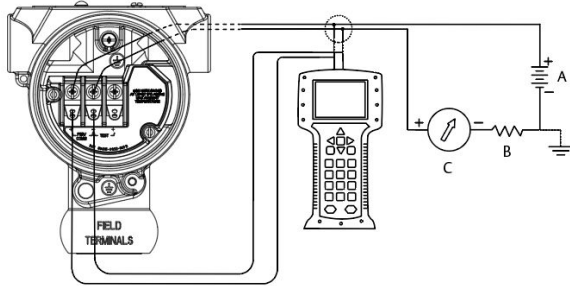

Polished 316 SST

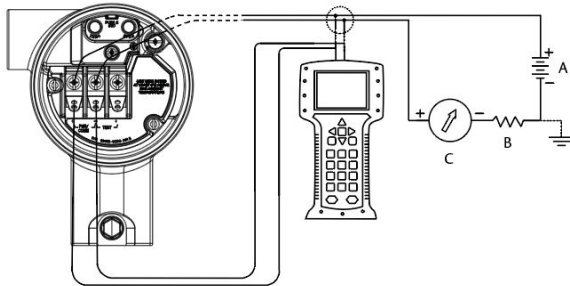

- A. 24 Vdc supply
- B. $R_L \geq 250$
- C. Current meter (optional)

Shielded twisted pair cable should be used for best results. Use 24 AWG or larger wire that does not exceed 5,000 ft. (1500 m) in length. If applicable, install wiring with a drip loop. Arrange the drip loop so the bottom is lower than the conduit connections and the transmitter housing.

⚠ CAUTION

- Installation of the transient protection terminal block does not provide transient protection unless the Rosemount 2051HT case is properly grounded.
- Do not run signal wiring in conduit or open trays with power wiring, or near heavy electrical equipment.
- Do not connect the powered signal wiring to the test terminals. Power could damage the test diode in the terminal block.

Use the following steps to wire the transmitter:

Procedure

1. Remove the housing cover on the FIELD TERMINALS side.
2. Connect the positive lead to the “+” terminal (PWR/COMM) and the negative lead to the “-” terminal.
3. Ensure full contact with Terminal Block screw and washer. When using a direct wiring method, wrap wire clockwise to ensure it is in place when tightening the terminal block screw.

Note

The use of a pin or a ferrule wire terminal is not recommended as the connection may be more susceptible to loosening over time or under vibration

4. Ground housing to fulfill local grounding regulations.
5. Ensure proper grounding. It is important the instrument cable shield be:
 - Trimmed close and insulated from touching the transmitter housing
 - Connected to the next shield if cable is routed through a junction box
 - Connected to a good earth ground at the power supply end
6. If transient protection is needed, refer to section “[Grounding for transient terminal block](#)” for grounding instructions.
7. Plug and seal unused conduit connections.
8. Reattach the transmitter covers. It is recommended that the cover be tightened until there is no gap between the cover and the housing.

The covers must only be capable of being released or removed with the aid of a tool to comply with applicable ordinary locations requirements.

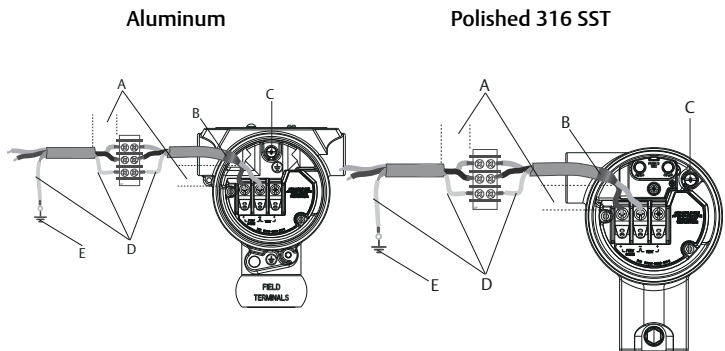
Figure 5-2: Wiring

- A. Minimize distance
- B. Trim shield and insulate
- C. Protective grounding terminal
- D. Insulate shield
- E. Connect shield back to the power supply ground

5.1 Grounding for transient terminal block

Ground termination is provided on the outside of the electronics housing and inside the terminal compartment. These grounds are used when the transient protection terminal blocks are installed. It is recommended that 18 AWG or larger wire is used to connect housing ground to earth ground (internal or external).

If the transmitter is currently not wired for power up and communication, follow [Connect the wiring and power up](#) step [Step 1](#) through [Step 8](#). When the transmitter is properly wired, refer to [Figure 5-2](#) for internal and external transient grounding locations.

Note

The Rosemount 2051HT polished 316 SST housing only provides ground termination inside the terminal compartment.

6 Verify configuration

Verify the configuration using any HART-capable configuration tool or Local Operator Interface (LOI) - option code M4. Configuration instructions for a Field Communicator and LOI are included in this step.

6.1 Verifying configuration with a Field Communicator

A Rosemount 2051 DD must be installed on the Field Communicator to verify configuration. Fast Key sequences for the latest DD are shown in [Table 6-1](#). For Fast Key sequences using legacy DD's, contact your local Emerson representative.

Note

Emerson recommends installing the latest DD to access the complete functionality. Visit [Emerson.com/Field-Communicator](https://emerson.com/Field-Communicator) for information on updating the DD Library.

Procedure

1. Verify device configuration using the Fast Key sequences in [Table 6-1](#).
2. A check (✓) indicates the basic configuration parameters. At minimum, these parameters should be verified as part of configuration and startup.

Table 6-1: Device Revision 9 and 10 (HART 7), DD Revision 1 Fast Key Sequence

	Function	HART 7	HART 5
✓	Alarm and Saturation Levels	2, 2, 2, 5, 7	2, 2, 2, 5, 7
✓	Damping	2, 2, 1, 1, 5	2, 2, 1, 1, 5
✓	Range Values	2, 2, 2	2, 2, 2
✓	Tag	2, 2, 7, 1, 1	2, 2, 7, 1, 1
✓	Transfer Function	2, 2, 1, 1, 6	2, 2, 1, 1, 6
✓	Units	2, 2, 1, 1, 4	2, 2, 1, 1, 4
	Burst Mode	2, 2, 5, 3	2, 2, 5, 3
	Custom Display Configuration	2, 2, 4	2, 2, 4
	Date	2, 2, 7, 1, 4	2, 2, 7, 1, 3
	Descriptor	2, 2, 7, 1, 5	2, 2, 7, 1, 4
	Digital to Analog Trim (4–20 mA output)	3, 4, 2	3, 4, 2

Table 6-1: Device Revision 9 and 10 (HART 7), DD Revision 1 Fast Key Sequence (continued)

	Function	HART 7	HART 5
	Disable Configuration Buttons	2, 2, 6, 3	2, 2, 6, 3
	Rerange with Keypad	2, 2, 2, 1	2, 2, 2, 1
	Loop Test	3, 5, 1	3, 5, 1
	Lower Sensor Trim	3, 4, 1, 2	3, 4, 1, 2
	Message	2, 2, 7, 1, 6	2, 2, 7, 1, 5
	Scaled D/A Trim (4–20 mA output)	3, 4, 2	3, 4, 2
	Sensor Temperature/Trend	3, 3, 2	3, 3, 2
	Upper Sensor Trim	3, 4, 1, 1	3, 4, 1, 1
	Digital Zero Trim	3, 4, 1, 3	3, 4, 1, 3
	Password	2, 2, 6, 5	2, 2, 6, 4
	Scaled Variable	3, 2, 2	3, 2, 2
	HART Revision 5 to HART Revision 7 switch	2, 2, 5, 2, 3	2, 2, 5, 2, 3
	Long Tag ⁽¹⁾	2, 2, 7, 1, 2	N/A
	Find Device ⁽¹⁾	3, 4, 5	N/A
	Simulate Digital Signal ⁽¹⁾	3, 4, 5	N/A

(1) Only available in HART Revision 7 mode.

6.2 Verifying configuration with LOI

The optional LOI can be used for commissioning the device. The LOI is a two-button design with internal and external/rear buttons. On a polished stainless steel housing, buttons are located internally both on the display and terminal side of the transmitter. On an aluminum housing, buttons are located on the display and externally underneath the top metal tag. To activate the LOI, push any button. LOI button functionality is shown on the bottom corners of the display. See [Table 6-2](#) and [Figure 6-2](#) for button operation and menu information.

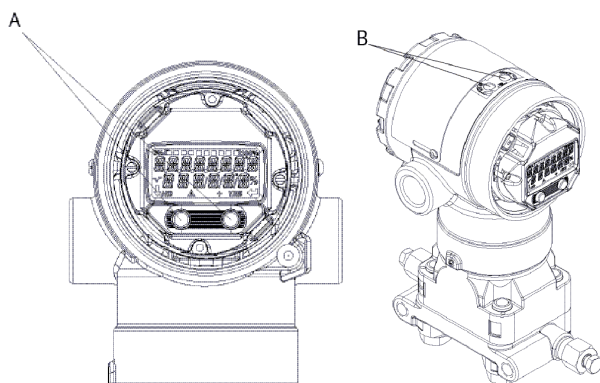
Figure 6-1: Internal and External LOI Buttons

A. Internal buttons

B. External buttons

Table 6-2: LOI Button Operation



Button		
Left	No	SCROLL
Right	Yes	ENTER

Figure 6-2: LOI Menu



6.3 Switch HART Revision mode

If the HART configuration tool is not capable of communicating with HART Revision 7, the Rosemount 2051 will load a generic menu with limited capability. The following procedures will switch the HART Revision mode from the generic menu:

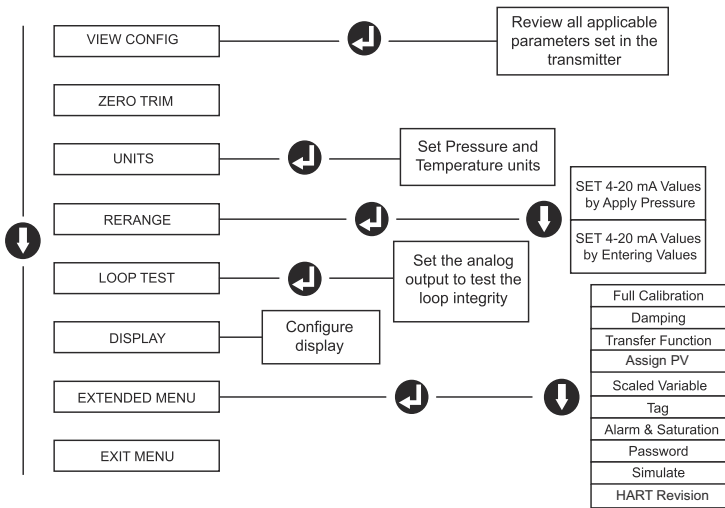
Procedure

Navigate to **Manual Setup** → **Device Information** → **Identification** → **Message**

- a) To change to HART Revision 5, Enter: **HART5** in the Message field.
- b) To change to HART Revision 7, Enter: **HART7** in the Message field.

Note

See [Table 6-1](#) to change HART Revision when the correct device driver is loaded.

7 Trim the transmitter

Devices are calibrated by the factory. Once installed, it is recommended to perform a zero trim on gage transmitters to eliminate error due to mounting position or static pressure effects. A zero trim can be performed using either a Field Communicator or configuration buttons.

Note

When performing a zero trim, ensure the equalization valve is open and all wet legs are filled to the correct level.

CAUTION

It is not recommended to zero an absolute transmitter, Rosemount 2051HTA model.

Procedure

Choose your trim procedure.

- a) Analog zero trim – Sets the analog output to 4 mA.
- b) Also referred to as a “rerange,” it sets the lower range value (LRV) equal to the measured pressure.
- c) The display and digital HART output remains unchanged.
- d) Digital zero trim – Recalibrates the sensor zero.
- e) The LRV is unaffected. The pressure value will be zero (on display and HART output). 4 mA point may not be at zero.
- f) This requires the factory calibrated zero pressure is within a range of 3% of the URV [$0 \pm 3\% \times \text{URV}$].

Example

$\text{URV} = 250 \text{ inH}_2\text{O}$ Applied Zero Pressure = $\pm 0.03 \times 250 \text{ inH}_2\text{O} = \pm 7.5 \text{ inH}_2\text{O}$
(compared to factory settings) values outside this range will be rejected by the transmitter

7.1 Trimming with a Field Communicator

Procedure

1. Connect the Field Communicator, see [Connect the wiring and power up](#) for instructions.
2. Follow the HART menu to perform the desired zero trim.

	Analog zero (set 4 mA)	Digital zero
Fast Key sequence	3, 4, 2	3, 4, 1, 3

7.2 Trimming with configuration buttons

A zero trim is to be performed using one of the three possible sets of configuration buttons located above the terminal block or under the top tag.

To access the configuration buttons on a polished stainless steel housing, remove the terminal side housing cover.

To access the configuration buttons on an aluminum housing, loosen the screw on the top tag and slide the tag on the top of the transmitter.

Figure 7-1: External or Rear/Terminal-Side Configuration Buttons

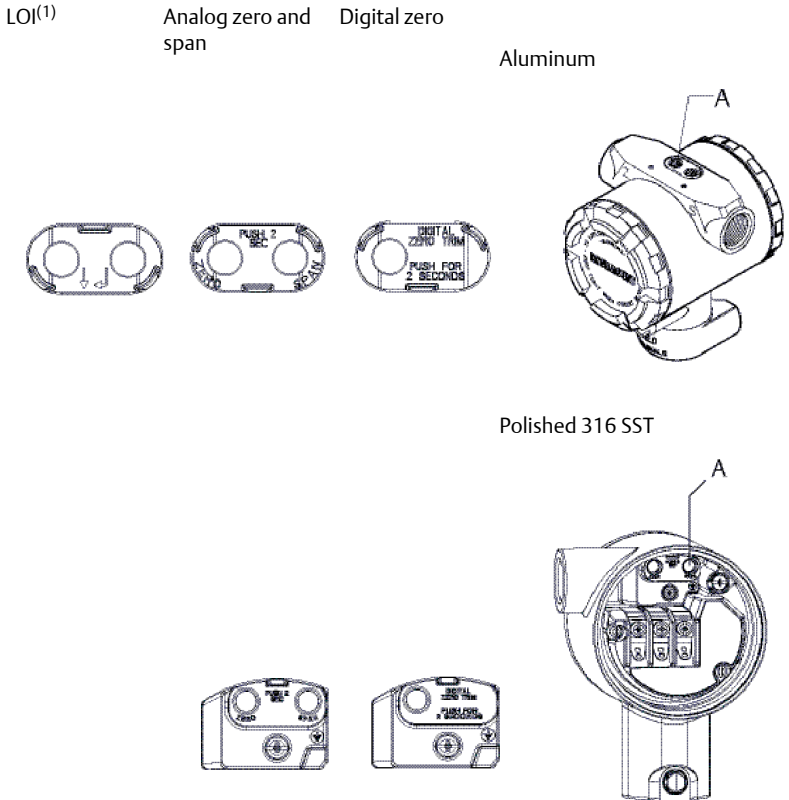

A. Configuration buttons

- (1) *LOI buttons (option M4) only offer front facing buttons on SST housing (option 1). Options D4 and DZ can still be purchased for rear/terminal-side facing buttons.*
-

Use one of the following procedures to perform a zero trim:

7.2.1 Perform trim with LOI (option M4)

Procedure

1. Set the transmitter pressure.
2. See [Figure 6-2](#) for the operating menu.
 - a) Perform an analog zero trim by selecting **Rerange**.
 - b) Perform a digital zero trim by selecting **Zero Trim**.

7.2.2 Perform trim with analog zero and span (option D4)

Procedure

1. Set the transmitter pressure.
2. Press and hold the Zero button for two seconds to perform an analog zero trim.

7.2.3 Perform trim with digital zero (option DZ)

Procedure

1. Set the transmitter pressure.
2. Press and hold the Zero button for two seconds to perform a digital zero trim.

8 Safety instrumented systems

For safety certified installations, refer to the Rosemount 2051 [Reference Manual](#) for installation procedure and system requirements.

9 Product certifications

Rev 1.14

9.1 European Directive Information

A copy of the EC Declaration of Conformity can be found at the end of the Quick Start Guide. The most recent revision of the EC Declaration of Conformity can be found at [EmersonProcess.com/Rosemount](https://www.emerson.com/Rosemount).

9.2 Ordinary Location Certification

As standard, the transmitter has been examined and tested to determine that the design meets the basic electrical, mechanical, and fire protection requirements by a nationally recognized test laboratory (NRTL) as accredited by the Federal Occupational Safety and Health Administration (OSHA).

9.3 North America

E5 USA Explosionproof (XP) and Dust-Ignitionproof (DIP)

Certificate: 3032938

Standards: FM Class 3600 – 2011, FM Class 3615 – 2006, FM Class 3616 – 2011, FM Class 3810 – 2005, ANSI/NEMA 250 – 2008, ANSI/IEC 60529 2004

Markings: XP CL I, DIV 1, GP B, C, D; DIP CL II, DIV 1, GP E, F, G; CL III; T5($-50\text{ }^{\circ}\text{C} \leq T_a \leq +85\text{ }^{\circ}\text{C}$); Factory Sealed; Type 4X

I5 USA Intrinsic Safety (IS) and Nonincendive (NI)

Certificate: 3033457

Standards: FM Class 3600 – 2011, FM Class 3610 – 2010, FM Class 3611 – 2004, FM Class 3810 – 2005, ANSI/NEMA 250 – 2008

Markings: IS CL I, DIV 1, GP A, B, C, D; CL II, DIV 1, GP E, F, G; Class III; DIV 1 when connected per Rosemount drawing 02051-1009; Class I, Zone 0; AEx ia IIC T4; NI CL 1, DIV 2, GP A, B, C, D; T4($-50\text{ }^{\circ}\text{C} \leq T_a \leq +70\text{ }^{\circ}\text{C}$); Type 4x

IE USA FISCO

Certificate: 3033457

Standards: FM Class 3600 – 2011, FM Class 3610 – 2010, FM Class 3611 – 2004, FM Class 3810 – 2005

Markings: IS CL I, DIV 1, GP A, B, C, D when connected per Rosemount drawing 02051-1009 ($-50\text{ °C} \leq T_a \leq +60\text{ °C}$); Type 4x

E6 Canada Explosion-Proof, Dust Ignition Proof

Certificate: 2041384

Standards: CAN/CSA C22.2 No. 0-10, CSA Std C22.2 No. 25-1966, CSA Std C22.2 No. 30-M1986, CAN/CSA-C22.2 No. 94-M91, CSA Std C22.2 No.142-M1987, CAN/CSA-C22.2 No.157-92, CSA Std C22.2 No. 213-M1987, CAN/CSA-E60079-0:07, CAN/CSA-E60079-1:07, CAN/CSA-E60079-11-02, CAN/CSA-C22.2 No. 60529:05, ANSI/ISA-12.27.01-2003

Markings: Explosion-Proof for Class I, Divisions 1, Groups B, C, and D. Dust-Ignition Proof for Class II and Class III, Division 1, Groups E, F, and G. Suitable for Class I, Division 2; Groups A, B, C, and D for indoor and outdoor hazardous locations. Class I Zone 1 Ex d IIC T5. Enclosure type 4X, factory sealed. Single Seal

I6 Canada Intrinsic Safety

Certificate: 2041384

Standards: CSA Std. C22.2 No. 142 - M1987, CSA Std. C22.2 No. 213 - M1987, CSA Std. C22.2 No. 157 - 92, CSA Std. C22.2 No. 213 - M1987, ANSI/ISA 12.27.01 – 2003, CAN/CSA-E60079-0:07, CAN/CSA-E60079-11:02

Markings: Intrinsically safe for Class I, Division 1, Groups A, B, C, and D when connected in accordance with Rosemount drawing 02051-1008. Ex ia IIC T3C. Single Seal. Enclosure Type 4X

9.4 Europe

E1 ATEX Flameproof

Certificate: KEMA 08ATEX0090X

Standards: EN60079-0:2006, EN60079-1:2007, EN60079-26:2007

Markings: Ⓜ II 1/2 G Ex d IIC T6 IP66 ($-50\text{ °C} \leq T_a \leq 65\text{ °C}$); Ⓜ II 1/2 G Ex d IIC T5 IP66 ($-50\text{ °C} \leq T_a \leq 80\text{ °C}$)

Special Conditions for Safe Use (X):

1. The Ex d blanking elements, cable glands and wiring needs to be suitable for a temperature of 90 °C.
2. This device contains a thin wall diaphragm. Installation, maintenance and use shall take into account the environmental conditions to

which the diaphragm will be subjected. The manufacturer's instructions for maintenance shall be followed in detail to assure safety during its expected lifetime.

- In case of repair, contact the manufacturer for information on the dimensions of the flameproof joints.

I1 ATEX Intrinsic Safety

Certificate: Baseefa08ATEX0129X

Standards: EN60079-0:2012, EN60079-11:2012

Markings: Ⓢ II 1 G Ex ia IIC T4 Ga ($-60\text{ °C} \leq T_a \leq +70\text{ °C}$)

Table 9-1: Input Parameters

Parameter	HART	Fieldbus/ PROFIBUS®
Voltage U_i	30 V	30 V
Current I_i	200 mA	300 mA
Power P_i	1 W	1.3 W
Capacitance C_i	0.012 μF	0 μF
Inductance L_i	0 mH	0 mH

Special Conditions for Safe Use (X):

- If the equipment is fitted with an optional 90 V transient suppressor, it is incapable of withstanding the 500 V isolation from earth test and this must be taken into account during installation.
- The enclosure may be made of aluminum alloy and given a protective polyurethane paint finish; however care should be taken to protect it from impact and abrasion when located in Zone 0.

IA ATEX FISCO

Certificate: Baseefa08ATEX0129X

Standards: EN60079-0:2012, EN60079-11:2012

Markings: Ⓢ II 1 G Ex ia IIC T4 Ga ($-60\text{ °C} \leq T_a \leq +60\text{ °C}$)

Table 9-2: Input Parameters

Parameter	FISCO
Voltage U_i	17.5 V
Current I_i	380 mA

Table 9-2: Input Parameters (continued)

Parameter	FISCO
Power P_i	5.32 W
Capacitance C_i	0 μ F
Inductance L_i	0 mH

Special Conditions for Safe Use (X):

1. If the equipment is fitted with an optional 90 V transient suppressor, it is incapable of withstanding the 500 V isolation from earth test and this must be taken into account during installation.
2. The enclosure may be made of aluminum alloy and given a protective polyurethane paint finish; however care should be taken to protect it from impact and abrasion when located in Zone 0.

N1 ATEX Type n

Certificate: Baseefa08ATEX0130X

Standards: EN60079-0:2012, EN60079-15:2010

Markings:  II 3G Ex nA IIC T4 Gc ($-40\text{ }^{\circ}\text{C} \leq T_a \leq +70\text{ }^{\circ}\text{C}$)

Special Conditions for Safe Use (X):

1. If the equipment is fitted with an optional 90 V transient suppressor, it is incapable of withstanding the 500 V electrical strength test as defined in clause 6.5.1 of by EN 60079-15:2010. This must be taken into account during installation.

ND ATEX Dust

Certificate: Baseefa08ATEX0182X

Standards: EN60079-0:2012, EN60079-31:2009

Markings:  II 1 D Ex ta IIIC T95 $^{\circ}\text{C}$ T₅₀₀ 105 $^{\circ}\text{C}$ Da ($-20\text{ }^{\circ}\text{C} \leq T_a \leq +85\text{ }^{\circ}\text{C}$)

Special Conditions for Safe Use (X):

1. If the equipment is fitted with an optional 90 V transient suppressor, it is incapable of withstanding the 500 V isolation from earth test and this must be taken into account during installation.

9.5 International

E7 IECEx Flameproof

Certificate: IECExKEM08.0024X

Standards: IEC60079-0:2004, IEC60079-1:2007-04, IEC60079-26:2006

Markings: Ex d IIC T6/T5 IP66, T6($-50\text{ °C} \leq T_a \leq +65\text{ °C}$), T5($-50\text{ °C} \leq T_a \leq +80\text{ °C}$)

Table 9-3: Process Temperature

Temperature class	Process temperature
T6	-50 °C to $+65\text{ °C}$
T5	-50 °C to $+80\text{ °C}$

Special Conditions for Safe Use (X):

1. The device contains a thin wall diaphragm. Installation, maintenance and use shall take into account the environmental conditions to which the diaphragm will be subjected. The manufacturer's instructions for maintenance shall be followed in detail to assure safety during its expected lifetime.
2. The Ex d blanking elements, cable glands, and wiring shall be suitable for a temperature of 90 °C .
3. In case of repair, contact the manufacturer for information on the dimensions of the flameproof joints.

I7 IECEx Intrinsic Safety

Certificate: IECExBAS08.0045X

Standards: IEC60079-0:2011, IEC60079-11:2011

Markings: Ex ia IIC T4 Ga ($-60\text{ °C} \leq T_a \leq +70\text{ °C}$)

Table 9-4: Input Parameters

Parameter	HART	Fieldbus/PROFIBUS
Voltage U_i	30 V	30 V
Current I_i	200 mA	300 mA
Power P_i	1 W	1.3 W
Capacitance C_i	0.012 μF	0 μF
Inductance L_i	0 mH	0 mH

Special Conditions for Safe Use (X):

1. If the equipment is fitted with an optional 90 V transient suppressor, it is incapable of withstanding the 500 V isolation from earth test and this must be taken into account during installation.
2. The enclosure may be made of aluminum alloy and given a protective polyurethane paint finish; however care should be taken to protect it from impact and abrasion when located in Zone 0.

IG IECEx FISCO

- Certificate:** IECExBAS08.0045X
Standards: IEC60079-0:2011, IEC60079-11:2011
Markings: Ex ia IIC T4 Ga (-60 °C ≤ T_a ≤ +60 °C)

Table 9-5: Input Parameters

Parameter	FISCO
Voltage U _i	17.5 V
Current I _i	380 mA
Power P _i	5.32 W
Capacitance C _i	0 μF
Inductance L _i	0 mH

Special Conditions for Safe Use (X):

1. If the equipment is fitted with an optional 90 V transient suppressor, it is incapable of withstanding the 500 V isolation from earth test and this must be taken into account during installation.
2. The enclosure may be made of aluminum alloy and given a protective polyurethane paint finish; however care should be taken to protect it from impact and abrasion when located in Zone 0.

N7 IECEx Type n

- Certificate:** IECExBAS08.0046X
Standards: IEC60079-0:2011, IEC60079-15:2010
Markings: Ex nA IIC T4 Gc (-40 °C ≤ T_a ≤ +70 °C)

Special Conditions for Safe Use (X):

1. If fitted with a 90 V transient suppressor, the equipment is not capable of withstanding the 500 V electrical strength test as defined

in clause 6.5.1 of IEC60079-15:2010. This must be taken into account during installation.

9.6 Brazil

E2 INMETRO Flameproof

Certificate: UL-BR 14.0375X

Standards: ABNT NBR IEC60079-0:2008 + Errata 1:2011, ABNT NBR IEC 60079-1:2009 + Errata 1:2011, ABNT NBR IEC 60079-26:2008 + Errata 1:2009

Markings: Ex d IIC T6/T5 Gb IP66, T6($-50\text{ °C} \leq T_a \leq +65\text{ °C}$), T5($-50\text{ °C} \leq T_a \leq +80\text{ °C}$)

Special Conditions for Safe Use (X):

1. The device contains a thin wall diaphragm. Installation, maintenance and use shall take into account the environmental conditions to which the diaphragm will be subjected. The manufacturer's instructions for installation and maintenance shall be followed in detail to assure safety during its expected lifetime.
2. The Ex d blanking elements, cable glands, and wiring shall be suitable for a temperature of 90 °C.
3. In case of repair, contact the manufacturer for information on the dimensions of the flameproof joints.

I2 INMETRO Intrinsic Safety

Certificate: UL-BR 14.0759X

Standards: ABNT NBR IEC 60079-0:2008 + Errata 1:2011; ABNT NBR IEC 60079-11:2009

Markings: Ex ia IIC T4 Ga ($-60\text{ °C} \leq T_a \leq +70\text{ °C}$)

Table 9-6: Input Parameters

Parameter	HART	Fieldbus/PROFIBUS
Voltage U_i	30 V	30 V
Current I_i	200 mA	300 mA
Power P_i	1 W	1.3 W
Capacitance C_i	12 nF	0
Inductance L_i	0	0

Special Conditions for Safe Use (X):

1. If the equipment is fitted with an optional 90 V transient suppressor, it is incapable of withstanding the 500 V insulation from earth test and this must be taken into account during installation.
2. The enclosure may be made of aluminium alloy and given a protective polyurethane paint finish; however care should be taken to protect it from impact and abrasion when located in atmospheres that require ELP Ga.

IB INMETRO FISCO

Certificate: UL-BR 14.0759X

Standards: ABNT NBR IEC 60079-0:2008 + Errata 1:2011; ABNT NBR IEC 60079-11:2009

Markings: Ex ia IIC T4 Ga (-60 °C ≤ T_a ≤ +60 °C)

Table 9-7: Input Parameters

Parameter	FISCO
Voltage U _i	17.5 V
Current I _i	380 mA
Power P _i	5.32 W
Capacitance C _i	0 nF
Inductance L _i	0 μH

Special Conditions for Safe Use (X):

1. If the equipment is fitted with an optional 90 V transient suppressor, it is incapable of withstanding the 500 V insulation from earth test and this must be taken into account during installation.
2. The enclosure may be made of aluminium alloy and given a protective polyurethane paint finish; however care should be taken to protect it from impact and abrasion when located in atmospheres that require ELP Ga.

9.7 China

E3 China Flameproof

Certificate: GYJ13.1386X; GYJ15.1366X [Flowmeters]

Standards: GB3836.1-2010, GB3836.2-2010, GB3836.20-2010-2010

Markings: Pressure Transmitter: Ex d IIC Gb, T6($-50\text{ }^{\circ}\text{C} \leq T_a \leq +65\text{ }^{\circ}\text{C}$),
 T5($-50\text{ }^{\circ}\text{C} \leq T_a \leq +80\text{ }^{\circ}\text{C}$)
 Flowmeter: Ex d IIC Ga/Gb, T6($-50\text{ }^{\circ}\text{C} \leq T_a \leq +65\text{ }^{\circ}\text{C}$), T5($-50\text{ }^{\circ}\text{C} \leq T_a \leq +80\text{ }^{\circ}\text{C}$)

Special Conditions for Safe Use (X):

1. Symbol “X” is used to denote specific conditions of use:
2. The Ex d blanking elements, cable glands, and wiring shall be suitable for a temperature of 90 °C.
3. This device contains a thin wall diaphragm. Installation, maintenance and use shall take into account the environment conditions to which the diaphragm will be subjected.
4. The relation between T code and ambient temperature range is:

T_a	Temperature class
$-50\text{ }^{\circ}\text{C} \leq T_a \leq +80\text{ }^{\circ}\text{C}$	T5
$-50\text{ }^{\circ}\text{C} \leq T_a \leq +65\text{ }^{\circ}\text{C}$	T6

5. The earth connection facility in the enclosure should be connected reliably.
6. During installation, use and maintenance of the product, observe the warning “Don’t open the cover when the circuit is alive.”
7. During installation, there should be no mixture harmful to flameproof housing
8. Cable entry and conduit, certified by NEPSI with type of protection Ex d IIC Gb and appropriate thread form, should be applied when installed in a hazardous location. Blanking elements should be used on the redundant cable entries.
9. End users are not permitted to change any internal components, but to settle the problem in conjunction with the manufacturer to avoid damage to the product.
10. Maintenance should be done in a non-hazardous location.
11. During installation, use and maintenance of this product, observe the following standards: GB3836.13-2013, GB3836.15-2000, GB3836.16-2006, GB50257-2014

I3 China Intrinsic Safety

Certificate: GYJ12.1295X; GYJ15.1365X [Flowmeters]

Standards: GB3836.1-2010, GB3836.4-2010, GB3836.20-2010

Markings: Ex ia IIC T4 Ga ($-60\text{ }^{\circ}\text{C} \leq T_a \leq +70\text{ }^{\circ}\text{C}$)

Special Conditions for Safe Use (X):

1. Symbol “X” is used to denote specific conditions of use:
2. If the apparatus is fitted with an optional 90 V transient suppressor, it is not capable of withstanding the 500 V insulation test for 1 minute. This must be taken into account when installing the apparatus.
3. The enclosure may be made of aluminum alloy and given a protective polyurethane paint finish; however, care should be taken to protect it from impact or abrasion if located in Zone 0.
4. The relation between T code and ambient temperature range is:

Model	T code	Temperature range
HART, Fieldbus, PROFIBUS, and Low Power	T4	$-60\text{ }^{\circ}\text{C} \leq T_a \leq +70\text{ }^{\circ}\text{C}$

5. Intrinsically Safe parameters:

Parameter	HART	Fieldbus/PROFIBUS
Voltage U_i	30 V	30 V
Current I_i	200 mA	300 mA
Power P_i	1 W	1.3 W
Capacitance C_i	0.012 μF	0 μF
Inductance L_i	0 mH	0 mH

Note

FISCO parameters comply with the requirements for FISCO field devices in GB3836.19-2010 [For Flowmeters] When Rosemount 644 Temperature Transmitter is used, the transmitter should be used with Ex-certified associated apparatus to establish explosion protection system that can be used in explosive gas atmospheres. Wiring and terminals should comply with the instruction manual of both Rosemount 644 and associated apparatus. The cables between Rosemount 644 and associated apparatus should be shielded cables (the cables must have insulated shield). The shielded cable has to be grounded reliably in a non-hazardous area.

6. The product should be used with Ex-certified associated apparatus to establish explosion protection system that can be used in explosive

gas atmospheres. Wiring and terminals should comply with the instruction manual of the product and associated apparatus.

7. The cables between this product and associated apparatus should be shielded cables (the cables must have insulated shield). The shielded cable has to be grounded reliably in a non-hazardous area.
8. End users are not permitted to change any internal components, and needs to settle the problem in conjunction with the manufacturer to avoid damage to the product.
9. During installation, use and maintenance of this product, observe the following standards: GB3836.13-2013, GB3836.15-2000, GB3836.16-2006, GB3836.18-2010, GB50257-2014.

9.8 Japan

E4 Japan Flameproof

Certificate: TC20598, TC20599, TC20602, TC20603 [HART]; TC20600, TC20601, TC20604, TC20605 [Fieldbus]

Markings: Ex d IIC T5

9.9 Technical Regulations Customs Union (EAC)

EM EAC Flameproof

Certificate: RU C-US.GB05.B.01199

Markings: Ga/Gb Ex d IIC X, T5($-50^{\circ}\text{C} \leq T_a \leq +80^{\circ}\text{C}$), T6($-50^{\circ}\text{C} \leq T_a \leq +65^{\circ}\text{C}$)

Special Conditions for Safe Use (X):

1. See certificate for special conditions.

IM EAC Intrinsically Safe

Certificate: RU C-US.GB05.B.01199

Markings: 0Ex ia IIC T4 Ga X ($-60^{\circ}\text{C} \leq T_a \leq +70^{\circ}\text{C}$)

Special Conditions for Safe Use (X):

1. See certificate for special conditions.

9.10 Combinations

K1 Combination of E1, I1, N1, and ND

K2 Combination of E2 and I2

K5 Combination of E5 and I5

K6 Combination of E6 and I6

K7 Combination of E7, I7, N7, and IECEx Dust

IECEx Dust

Certificate: IECEx BAS 08.0058X

Standards: IEC60079-0:2011, IEC60079-31:2008

Markings: Ex ta IIIC T95 °C T₅₀₀105 °C Da (-20 °C ≤ T_a ≤ +85 °C)

Special Condition for Safe Use (X):

1. If the equipment is fitted with an optional 90 V transient suppressor, it is incapable of withstanding a 500 V isolation from earth test and this must be taken into account during installation.

KA Combination of E1, I1, and K6

KB Combination of K5 and K6

KC Combination of E1, I1, and K5

KD Combination of K1, K5, and K6

KM Combination of EM and IM

9.11 Additional Certifications

SBS American Bureau of Shipping (ABS) Type Approval

Certificate: 09-HS446883B-3-PDA

Intended Use: Marine and Offshore Applications – Measurement of either Gauge or Absolute Pressure for Liquid, Gas, and Vapor.

ABS Rules: 2013 Steel Vessels Rules 1-1-4/7.7, 1-1-Appendix 3, 4-8-3/1.7, 4-8-3/13.1

SBV Bureau Veritas (BV) Type Approval

Certificate: 23157/B0 BV

BV Rules: Bureau Veritas Rules for the Classification of Steel Ships

Application: Class notations: AUT-UMS, AUT-CCS, AUT-PORT and AUT-IMS; Pressure transmitter type 2051 cannot be installed on diesel engines

SDN Det Norske Veritas (DNV) Type Approval

Certificate: TAA000004F

Intended Use: DNV GL Rules for Classification - Ships and offshore units

Application:



Location classes	
Type	2051
Temperature	D
Humidity	B
Vibration	A
EMC	B
Enclosure	D



SLL Lloyds Register (LR) Type Approval



Certificate: 11/60002

Application: Environmental categories ENV1, ENV2, ENV3 and ENV5

Figure 9-1: Rosemount 2051 Declaration of Conformity

	<h2 style="text-align: center;">EU Declaration of Conformity</h2>	
<p>No: RMD 1071 Rev. N</p>		
<p>We,</p>		
<p>Rosemount, Inc. 8200 Market Boulevard Chanhassen, MN 55317-9685 USA</p>		
<p>declare under our sole responsibility that the product,</p>		
<p>Rosemount™ Model 2051 Pressure Transmitter</p>		
<p>manufactured by,</p>		
<p>Rosemount, Inc. 8200 Market Boulevard Chanhassen, MN 55317-9685 USA</p>		
<p>to which this declaration relates, is in conformity with the provisions of the European Union Directives, including the latest amendments, as shown in the attached schedule.</p>		
<p>Assumption of conformity is based on the application of the harmonized standards and, when applicable or required, a European Union notified body certification, as shown in the attached schedule.</p>		
	<p><u>Vice President of Global Quality</u> (function)</p>	
<p><u>Chris LaPoint</u> (name)</p>	<p><u>28-Feb-20 ; Shakopee, MN USA</u> (date of issue & place)</p>	
<p>Page 1 of 3</p>		

	<h2>EU Declaration of Conformity</h2>	
<p>No: RMD 1071 Rev. N</p>		
<p>EMC Directive (2014/30/EU)</p>		
<p>Harmonized Standards: EN 61326-1:2013, EN 61326-2-3:2013</p>		
<p>PED Directive (2014/68/EU)</p>		
<p>Rosemount 2051CD2, 3, 4, 5 (also with P9 option) QS Certificate of Assessment - Certificate No. 12698-2018-CE-ACCREDIA Module H Conformity Assessment Other Standards Used: ANSI / ISA 61010-1:2004 <i>Note – previous PED Certificate No. 59552-2009-CE-HOU-DNV</i></p>		
<p>All other Rosemount 2051 Pressure Transmitters Sound Engineering Practice</p>		
<p>Transmitter Attachments: Diaphragm Seal, Process Flange, or Manifold Sound Engineering Practice</p>		
<p>Rosemount 2051Ex DP Flowmeter See DSI 1000 Declaration of Conformity</p>		
<p>ATEX Directive (2014/34/EU)</p>		
<p>Baseefa08ATEX0129X - Intrinsic Safety Certificate Equipment Group II Category 1 G Ex ia IIC T4 Ga Harmonized Standards Used: EN60079-0:2012+A.11:2013, EN60079-11:2012</p>		
<p>Baseefa08ATEX0130X - Type n Certificate Equipment Group II Category 3 G Ex nA IIC T4 Gc Harmonized Standards Used: EN60079-0:2012+A.11:2013, EN60079-15:2010</p>		
<p>KEMA08ATEX0090X - Flameproof Certificate Equipment Group II Category 1/2 G Ex db IIC T6... T4 Ga/Gb Harmonized Standards Used: EN60079-0:2012+A.11:2013, EN60079-1:2014, EN60079-26:2015</p>		
<p>Baseefa08ATEX0182X - Dust Certificate Equipment Group II Category 1 D Ex ta IIIc T95°C T300/105°C Da Harmonized Standards Used: EN60079-0:2012+A.11:2013, EN60079-31:2014</p>		
<p>Page 2 of 3</p>		

	EU Declaration of Conformity No: RMD 1071 Rev. N	
RoHS Directive (2011/65/EU) Model 2051 with 4-20 mA HART protocol only (output code A) Harmonized Standards: EN 50581:2012		
PED Notified Body DNV GL Business Assurance Italia S.r.l. [Notified Body Number: 0496] Via Energy Park, 14, N-20871 Vimercate (MB), Italy <i>Note – equipment manufactured prior to 20 October 2018 may be marked with the previous PED Notified Body number; previous PED Notified Body information was as follows: Det Norske Veritas (DNV) [Notified Body Number: 0575] Veritasveien 1, N-1322 Hovik, Norway</i>		
A TEX Notified Bodies DEKRA (KEMA) [Notified Body Number: 0344] Meander 1051 6825 MJ Arnhem The Netherlands SGS FIMCO OY [Notified Body Number: 0598] P.O. Box 30 (Sarkiniementie 3) 00211 HELSINKI Finland		
A TEX Notified Body for Quality Assurance SGS FIMCO OY [Notified Body Number: 0598] P.O. Box 30 (Sarkiniementie 3) 00211 HELSINKI Finland		
Page 3 of 3		

9.12 China RoHS

有害物质成分表
03031-9021, Rev AA

罗斯蒙特产品型号 2051
7/1/2016

含有China RoHS管控物质超过最大浓度限值的部件型号列表 2051
List of 2051 Parts with China RoHS Concentration above MCVs

部件名称 Part Name	有害物质 / Hazardous Substances					
	铅 Lead (Pb)	汞 Mercury (Hg)	镉 Cadmium (Cd)	六价铬 Hexavalent Chromium (Cr +6)	多溴联苯 Polybrominated biphenyls (PBB)	多溴联苯醚 Polybrominated diphenyl ethers (PBDE)
电子组件 Electronics Assembly	X	O	O	O	O	O
壳体组件 Housing Assembly	X	O	O	X	O	O
传感器组件 Sensor Assembly	X	O	O	X	O	O

本表格系依据SJ/T11364的规定而制作。

This table is proposed in accordance with the provision of SJ/T11364.

O: 意为该部件的所有均质材料中该有害物质的含量均低于GB/T 26572所规定的限量要求。

O: Indicate that said hazardous substance in all of the homogeneous materials for this part is below the limit requirement of GB/T 26572.

X: 意为在该部件所使用的的所有均质材料里，至少有一类均质材料中该有害物质的含量高于GB/T 26572所规定的限量要求。

X: Indicate that said hazardous substance contained in at least one of the homogeneous materials used for this part is above the limit requirement of GB/T 26572.

部件名称 Part Name	组装备件说明 Spare Parts Descriptions for Assemblies
电子组件 Electronics Assembly	电子线路板组件 Electronic Board Assemblies 端子块组件 Terminal Block Assemblies 升级套件 Upgrade Kits 液晶显示屏或本地操作界面 LCD or LOI Display
壳体组件 Housing Assembly	电子外壳 Electrical Housing
传感器组件 Sensor Assembly	传感器模块 Sensor Module



Global Headquarters

Emerson Automation Solutions
6021 Innovation Blvd.
Shakopee, MN 55379, USA

- +1 800 999 9307 or +1 952 906 8888
- +1 952 204 8889
- RFQ.RMD-RCC@Emerson.com

Latin America Regional Office

Emerson Automation Solutions
1300 Concord Terrace, Suite 400
Sunrise, FL 33323, USA

- +1 954 846 5030
- +1 954 846 5121
- RFQ.RMD-RCC@Emerson.com

Asia Pacific Regional Office

Emerson Automation Solutions
1 Pandan Crescent
Singapore 128461

- +65 6777 8211
- +65 6777 0947
- Enquiries@AP.Emerson.com

 [Linkedin.com/company/Emerson-Automation-Solutions](https://www.linkedin.com/company/Emerson-Automation-Solutions)

 [Twitter.com/Rosemount_News](https://twitter.com/Rosemount_News)

 [Facebook.com/Rosemount](https://www.facebook.com/Rosemount)

 [Youtube.com/user/RosemountMeasurement](https://www.youtube.com/user/RosemountMeasurement)

North America Regional Office

Emerson Automation Solutions
8200 Market Blvd.
Chanhassen, MN 55317, USA

- +1 800 999 9307 or +1 952 906 8888
- +1 952 204 8889
- RMT-NA.RCCRFQ@Emerson.com

Europe Regional Office

Emerson Automation Solutions Europe
GmbH
Neuhofstrasse 19a P.O. Box 1046
CH 6340 Baar
Switzerland

- +41 (0) 41 768 6111
- +41 (0) 41 768 6300
- RFQ.RMD-RCC@Emerson.com

Middle East and Africa Regional Office

Emerson Automation Solutions
Emerson FZE P.O. Box 17033
Jebel Ali Free Zone - South 2
Dubai, United Arab Emirates

- +971 4 8118100
- +971 4 8865465
- RFQ.RMTMEA@Emerson.com

©2020 Emerson. All rights reserved.

Emerson Terms and Conditions of Sale are available upon request. The Emerson logo is a trademark and service mark of Emerson Electric Co. Rosemount is a mark of one of the Emerson family of companies. All other marks are the property of their respective owners.